

TECHNICAL GUIDE

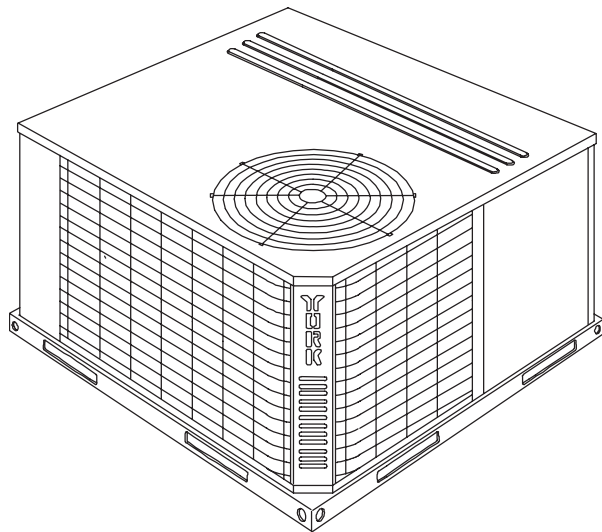

Heating and Air Conditioning



CHAMPION® ULTRA

SINGLE PACKAGE HEAT PUMPS

BHP024 THRU 060
2 THRU 5 NOMINAL TONS
13 SEER

FACTORY MOUNTED TXV

DESCRIPTION

These packaged heat pumps are designed for outdoor installation. Only utility and duct connections are required at the point of installation.

Field-installed electric heater accessories are available to provide electric heat, if required.

STANDARD FEATURES / BENEFITS

OPERATING EFFICIENCY

All units provide high operating efficiencies of 13 SEER, 3.3 COP or greater, and 7.6 HSPF. All efficiencies exceed legislated minimum levels.

ON SITE FLEXIBILITY

All model sizes share a common, compact design cabinet with a single footprint. The installer has the flexibility of setting one curb or pad and placing the proper tonnage unit after the internal load has been determined. Field convertible duct connections, from side shot to down shot, allows the installer greater flexibility and the need to carry less inventory.

LOWER INSTALLATION COST

Installation time and costs are reduced by easy power and control wiring connections. The small base dimension means less space is required on the ground or roof. Plus, the installer can fit this unit between the wheel wells of full size pick-up truck. All models are under 500 pounds.

All units are completely wired, charged with R-22 and tested prior to shipment. Unique test stations, are used to insure product quality. Refrigerant charge, and component part numbers are verified via computers at manufacturing point. Vital run test statistics, such as, system pressure, motor currents, air velocity and temperature unit vibration are monitored and recorded by the system to insure unit performance.

Equal size, side supply and return duct connections allow easy hook-up of ducts to match low crawl spaces without transition pieces.

UTILITY CONNECTIONS MADE EASY

Electrical utility knockouts are provided through the bottom, as well as the side of the unit. Utility connections can be made quickly and with a minimum amount of field labor. A field supplied and field installed electrical disconnect switch must be installed.

CONVERTIBLE AIRFLOW DESIGN

The bottom duct openings are covered when they leave the factory. They are ready for a side supply / side return application. If a bottom supply / bottom return application is desired, you simply remove the two panels from the bottom of the unit and place them in the side supply / side return duct openings. No panel cutting is required and no accessory panel is necessary. Convertible airflow design allows maximum field flexibility and minimum inventory.

CONDENSATE PAN

A non-corrosive, long-lasting, water-tight pan is positioned below the evaporator coil to collect and drain all condensate; less collection of stagnate condensate will build-up. The condensate pan conforms to ASHRAE 62-89 standards (Ventilation for Acceptable Indoor Air Quality).

CONDENSATE DRAIN

The heavy duty, 1/2 inch NPTI copper connection is more tolerable during installation and is more durable over time. The connection is rigidly mounted to assure proper fit and leak tight seal.

DURABLE FINISH

With a heavy duty cabinet made of powder-painted, galvanized steel, the neutral color blends into surrounding areas. The powered paint provides a better paint to steel bond, which resists corrosion and rust creep. The special primer formulas and glossy earth tone finish insure less fading when exposed to sunlight and offers a more attractive on site appearance. This paint finish exceeds ASTM-B117 standards for 1000 hours salt spray rating, the highest in the industry.

FULL PERIMETER BASE RAILS

The easily removable base rails provide a solid foundation for the entire unit and protects the unit during shipment. The rails provide fork lift access from all sides. Rigging holes are, provided also so that an overhead crane can be used to place the unit on a roof. On applications when the unit is placed on a pad, the base will keep the unit off the pad to deter corrosion. On applications where height is limited, the 2-3/8 inch high base rails may be removed on location.

MORE ATTRACTIVE APPEARANCE

A single piece "Water Shed" top cover containing a top discharge condenser fan arrangement requires less square footage on installation and provides a wider variety of installations. The one piece design adds greater water integrity. Rounded corners with water drip edges add to the attractive appearance. The cabinet panels have a non-fibrous insulation that reduces insulation fibers into conditioned area.

TOP DISCHARGE

The top discharge condenser fan does not disrupt neighboring areas and does not dry-out vegetation surrounding the unit. The warm air from the top mounted fan is blown up away from the structure and any landscaping. This allows compact location on multi-unit applications.

OUTDOOR COIL GRILLE

A multi-piece totally enclosed, rigidly mounted outdoor coil grille provides protection from objects and personnel after installation. It also provides protection during transit and installation.

LOW OPERATING SOUND LEVEL

The upward air flow carries the normal operating noise up and away from the living area. The rigid top panel effectively isolates any motor sound. Isolator mounted compressor and the rippled fins of the condenser coil, muffle the normal fan motor and compressor operating sounds. The unique formed base pan also aids in sound alterations with its "Super-Structure" design. This design strategically places embossments in the pan for optimum strength and rigidity.

FAN SYSTEM

All models operate over a wide range of design conditions with an (E.C.M.) electronically commutated motor that automatically adjusts the blower speed to meet a wide range of static requirements. These units easily match all types of applications and provides greater on site flexibility to match comfort requirements.

SIMPLE CONTROL CIRCUIT

A low voltage printed circuit board contains a low voltage terminal strip. The electrical control box is not located in the compressor compartment. All wiring internal to the unit is color/number coded.

CONTROLS

Reliable demand defrost control provides defrost. Defrost control also provides an "X" terminal to provide a 24 volt signal for room thermostat "LED" indication of unit lockout, plus, built in 5 minute anti-short cycle protection.

PROTECTED COMPRESSOR

The compressor is internally protected against high pressure and temperature. This is accomplished by the simultaneous operation of high pressure relief valve and a temperature sensor which protects the compressor, if undesirable operating conditions occur.

EXCLUSIVE COIL DESIGN

Grooved copper tubes and enhanced aluminum fin construction improves heat transfer for maximum efficiency and durability.

LOW MAINTENANCE

Long life, permanently lubricated condenser and evaporator fan motor bearings, need no annual maintenance. Blower assembly can be easily cleaned by the unique "Slip Track" slide-out blower assembly.

SECURED SERVICE ACCESS PORTS

Protected, externally mounted, re-usable service access ports are provided on both the high and low lines for ease of evacuating and charging the system.

EASY SERVICE ACCESS

A large, single hinged panel covers the electrical controls and makes servicing easy. The blower compartment has an additional large panel with a built-in handle tab. Removing this panel will allow the blower assembly to slide-out for easy removal for maintenance and ease of trouble shooting.

REPLACEMENT PARTS

The installer has no need to carry an inventory of unique parts or needs special training to replace any of the components parts for these units. All are easily obtained from Source 1 or other major part houses.

FIELD-INSTALLED ACCESSORIES

ECONOMIZER DOWN DISCHARGE / SUPPLY KIT

Modulating integrated economizer provides simultaneous operation between the mechanical cooling and economizer operation. Independent blade design insures proper control and less than 1% leak rate. Includes hood and mesh bird screen filter integrated into the hood, dry bulb sensor and relief damper. Sepa-

rate field accessories of single enthalpy and dual enthalpy are also available.

SINGLE ENTHALPY SENSOR

Sensor replaces dry bulb sensor standard in economizer kit. Provides improved economizer operation by sensing the dry bulb temperature from outdoors, plus the enthalpy content of the outdoor air.

DUAL ENTHALPY SENSOR

Additional sensor to single enthalpy sensor. Sensor selects both the return air temperature dry bulb and humidity, in conjunction with the single enthalpy, to determine the most economical mix. Single Enthalpy sensor also required.

UPGRADE PRESSURE PACKAGE

Contains screw in type High pressure, Low Pressure/Loss of Charge switch, freeze protection switch and lockout relay. Switches are placed onto existing Schrader ports located in the unit by furnished adapters. When abnormal conditions are sensed through the pressure switches, the unit will lock out, preventing any further operation until reset or problem is corrected. Package agency approved.

HAIL GUARD KIT

Kit contains protected grilles made of expanded aluminum grilles with full perimeter 1-1/2 inch frame. Sloped hoods are also included to assure maximum protection.

FILTER / FRAME KIT (SINGLE PHASE ONLY)

Kit contains the necessary hardware to field install return air filters into the base unit. Pre-cut filter racks and appropriate cleanable standard size filters are shipped in one kit (1" filter is supplied). This kit is available for single phase horizontal or vertical duct application only. Standard in all 3 Phase models.

MOTORIZED FRESH AIR DAMPER

Designed for duct mounted side return and unit mounted down shot return applications. Damper capable of providing 0% thru 50% of outdoor air (field supplied). Closes on power loss, includes hood and screen assembly.

RECTANGLE TO ROUND ADAPTERS

Kit includes one supply and one return air rectangle to round duct adapter. Adapters are preformed and designed to fit over current duct openings on the base unit. Transition is from 15" square to 14" round.

ROOF CURBS

NRCA approved curbs provide proper fit to base unit for rooftop installations. Curbs are designed to be assembled through hinge pins in each corner. Kit also provides seal strip to assure a water tight seal. Eight and 14 inch high roof curbs are available.

MANUAL OUTDOOR DAMPER

Provides 0% thru 50% outdoor air capability (field adjustable). Designed for duct mounted side return and

unit mounted down shot applications. Includes hood and screen assembly.

WALL THERMOSTAT

The units are designed to operate with 24-volt electronic and electro-mechanical thermostats. All units can operate with single stage heat / single stage cool thermostats - with or without the economizer.

ELECTRIC HEATERS

Each heater package provides easy installation of electric heat strips. Slide in design with plug in harness and agency approved. Heaters are available from 5.0 KW sizes and are designed for single point and dual connection.

TABLE OF CONTENTS

Description	1	Heating Capacities - 5 Ton (BHP060)	14
Standard Features / Benefits	1	Side & Bot. Sup. Air Blower Perf. (208/230/460 Volt)	15
Field-installed Accessories	3	Additional Static Resistance	15
Unit Cut Away	5	Field Wiring Diagram	16
Ratings	5	Electrical Data (Basic Unit)	17
Physical Data	5	Electrical Data (13 Seer Heat Pump / Electric Heat)	18
Cooling Capacities - 2 Ton (BHP024)	6	Application Data	19
Cooling Capacities - 2-1/2 Ton (BHP030)	7	Center of Gravity and Weights	19
Cooling Capacities - 3 Ton (BHP036)	8	Unit Clearances	19
Cooling Capacities - 3-1/2 Ton (BHP042)	9	Unit Dimensions	20
Cooling Capacities - 4 Ton (BHP048)	10	Typical Applications	21
Cooling Capacities - 5 Ton (BHP060)	11	Roof Curb Dimensions	22
Heating Capacities - 2 Ton (BHP024)	12	Typical Wiring Diagram (208/230-1-60 Power Supply)	23
Heating Capacities - 2-1/2 Ton (BHP030)	12	Typical Wiring Diagram (230-3-60 Power Supply)	24
Heating Capacities - 3 Ton (BHP036)	13	Typical Wiring Diagram (460-3-60 Power Supply)	25
Heating Capacities - 3-1/2 Ton (BHP042)	13	Mechanical Specifications	26
Heating Capacities - 4 Ton (BHP048)	14		

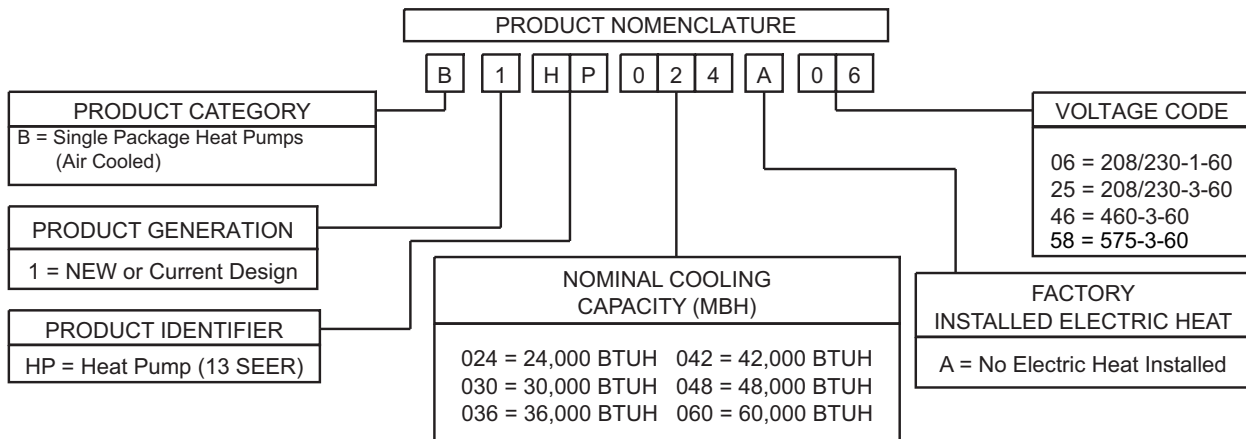

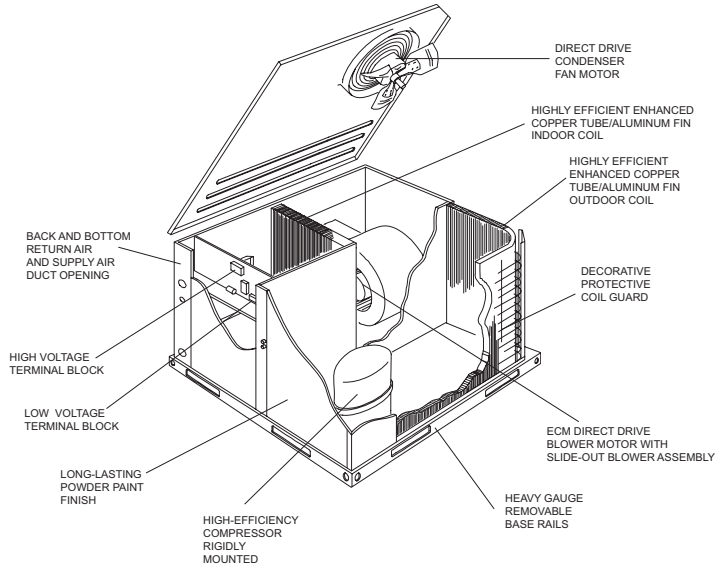

FIGURE 1 - UNIT CUT AWAY

TABLE 1: RATINGS

MODEL BHP	COOLING CAPACITY ¹ 80 / 67-95°F			HSPF ¹	SOUND RATING ² (dbels)	NET HEATING CAPACITY				AVAILABLE ELECTRIC HEAT NOMINAL CAPACITY KW	
	MBH	SEER	EER			@47°F		@17°F		SINGLE PHASE	THREE PHASE
						MBH	COP	MBH	COP		
024	24.4	13.0	11.3	7.6	79	21.8	3.40	11.0	2.00	5.0, 7.5, 10.0	N / A
030	30.0	13.0	11.3	7.6	77	28.2	3.40	16.5	2.20	5.0, 7.5, 10.0, 15.0	10.0, 15.0
036	35.5	13.0	11.3	7.6	77	32.0	3.30	18.9	2.20	5.0, 7.5, 10.0, 15.0	10.0, 15.0
042	42.0	13.0	11.3	7.6	83	42.0	3.40	23.0	2.20	10.0, 15.0	10.0, 15.0
048	47.0	13.0	11.3	7.6	82	45.0	3.30	25.8	2.20	10.0, 15.0, 20.0, 25.0	10.0, 15.0, 20.0, 25.0
060	55.0	13.0	11.2	7.7	83	56.5	3.30	33.2	2.15	10.0, 15.0, 20.0, 25.0	10.0, 15.0, 20.0, 25.0

1. Certified in accordance with the Uniary Small Equipment certification program, which is based on ARI Standard 210/240.

2. Rated in accordance with ARI Standard 270.

SEER =Seasonal Energy Efficiency Ratio - the total cooling output in BTU's during a normal annual usage period for cooling divided by the total electric power input in watt-hours during the same period.

COP = Coefficient of Performance - the total heating capacity provided by the refrigeration system, including circulating fan heat but excluding supplementary resistance (BTU's per hour) divided by the total electric input (watts) x 3.412.

TABLE 2: PHYSICAL DATA

MODELS		BHP					
		024	030	036	042	048	060
INDOOR BLOWER	CENTRIFUGAL BLOWER (Dia. x Wd. in.)	10 X 8	10 X 8	11 x 10	11 x 10	11 X 10	11 X 10
	FAN MOTOR HP (ECM)	1/2	1/2	3/4	3/4	3/4	1
INDOOR COIL	ROWS DEEP	2	3	3	3	3	3
	FINS PER INCH	15	13	15	16	16	16
	FACE AREA (Sq. Ft.)	4.38	4.38	4.38	5.63	5.63	5.63
OUTDOOR FAN	PROPELLER DIA. (in.)	22	22	22	22	22	22
	FAN MOTOR HP	1/4	1/4	1/4	1/4	1/4	1/2
	NOM. CFM TOTAL	1,800	1,800	2,400	2,400	3,000	3,000
OUTDOOR COIL	ROWS DEEP	1	1	2	2	2	2
	FINS PER INCH	20	20	20	20	20	20
	FACE AREA (Sq. Ft.)	11.7	11.7	11.7	16.4	16.4	16.4
CHARGE	REFRIGERANT 22 (lbs./oz.)	5 / 5	5 / 15	8 / 4	9 / 14	12 / 0	10 / 4
FILTER	FACE AREA (Sq. Ft. / Qty. / Size)	4.28 / 2 / 14 x 22					
COMPRESSOR	Hermetic Type, Qty. = 1	Reciprocating	Scroll	Scroll	Scroll	Scroll	Scroll

TABLE 3: COOLING CAPACITIES - 2 TON (BHP024)

TEMPERATURE AIR ON OUTDOOR COIL			TEMPERATURE OF AIR ON INDOOR COIL								
			800 CFM				900 CFM				
			WB °F				WB °F				
			72	67	62	57	72	67	62	57	
85 °F	NET CAP. MBH		29.1	26.0	23.8	23.4	29.7	26.6	24.3	23.9	
	POWER INPUT kW		1.93	1.91	1.88	1.87	1.95	1.93	1.91	1.90	
	Sensible Capacity MBH ¹	Entering Dry Bulb °F	86	19.2	23.1	23.8	23.4	20.9	25.1	24.3	23.9
			83	16.9	20.8	23.8	23.4	18.3	22.5	24.3	23.9
			80	14.5	18.5	21.9	22.7	15.6	19.8	23.4	23.6
			77	12.2	16.1	19.5	20.3	12.9	17.2	20.7	20.9
			74	9.9	13.8	17.2	18.0	10.3	14.5	18.0	18.2
			71	#N/A	11.5	14.9	15.7	#N/A	11.9	15.4	15.6
68	#N/A	9.1	12.5	13.3	#N/A	9.2	12.7	12.9			
95 °F	NET CAP. MBH		27.2	24.2	22.1	22.0	27.7	24.6	22.5	22.4	
	POWER INPUT kW		2.07	2.06	2.02	2.02	2.09	2.08	2.05	2.04	
	Sensible Capacity MBH ¹	Entering Dry Bulb °F	86	18.6	22.3	22.1	22.0	20.1	23.7	22.5	22.4
			83	16.2	20.0	22.1	22.0	17.5	21.5	22.5	22.4
			80	13.9	17.7	20.8	21.4	14.8	18.9	21.8	22.1
			77	11.6	15.3	18.4	19.0	12.2	16.2	19.2	19.4
			74	9.2	13.0	16.1	16.7	9.5	13.5	16.5	16.8
			71	#N/A	10.7	13.8	14.4	#N/A	10.9	13.8	14.1
68	#N/A	8.3	11.4	12.0	#N/A	8.2	11.2	11.5			
105 °F	NET CAP. MBH		23.8	22.4	20.5	20.6	24.2	22.8	20.8	20.9	
	POWER INPUT kW		2.20	2.21	2.17	2.16	2.24	2.24	2.20	2.19	
	Sensible Capacity MBH ¹	Entering Dry Bulb °F	86	19.5	21.5	20.5	20.6	20.4	22.3	20.8	20.9
			83	17.2	19.2	20.5	20.6	18.5	20.7	20.8	20.9
			80	14.9	16.9	19.7	20.0	15.9	18.1	20.4	20.6
			77	12.6	14.6	17.4	17.7	13.3	15.4	17.8	18.0
			74	10.2	12.2	15.1	15.3	10.6	12.7	15.1	15.3
			71	#N/A	9.9	12.7	13.0	#N/A	10.1	12.4	12.6
68	#N/A	7.6	10.4	10.7	#N/A	7.4	9.8	10.0			
115 °F	NET CAP. MBH		20.4	20.7	18.9	19.2	20.6	20.9	19.1	19.4	
	POWER INPUT kW		2.34	2.36	2.32	2.31	2.38	2.40	2.36	2.35	
	Sensible Capacity MBH ¹	Entering Dry Bulb °F	86	20.4	20.7	18.9	19.2	20.6	20.9	19.1	19.4
			83	18.2	18.5	18.9	19.2	19.5	19.8	19.1	19.4
			80	15.9	16.1	18.7	18.6	17.0	17.3	19.0	19.1
			77	13.6	13.8	16.4	16.3	14.4	14.6	16.4	16.5
			74	11.2	11.5	14.1	14.0	11.7	11.9	13.7	13.8
			71	#N/A	9.1	11.7	11.6	#N/A	9.3	11.1	11.2
68	#N/A	6.8	9.4	9.3	#N/A	6.6	8.4	8.5			
125 °F	NET CAP. MBH		17.0	18.9	17.3	17.8	17.0	19.0	17.5	17.9	
	POWER INPUT kW		2.47	2.51	2.46	2.45	2.52	2.56	2.51	2.50	
	Sensible Capacity MBH ¹	Entering Dry Bulb °F	86	21.3	19.9	17.3	17.8	20.8	19.5	17.5	17.9
			83	19.2	17.7	17.3	17.8	20.6	18.9	17.5	17.9
			80	16.9	15.4	17.7	17.3	18.1	16.5	17.6	17.7
			77	14.6	13.0	15.4	15.0	15.4	13.8	15.0	15.0
			74	12.2	10.7	13.1	12.6	12.8	11.1	12.3	12.3
			71	#N/A	8.4	10.7	10.3	#N/A	8.5	9.7	9.7
68	#N/A	6.0	8.4	8.0	#N/A	5.8	7.0	7.0			

1. These capacities are net capacities - indoor fan heat deducted.

 ALL SENSIBLE CAPACITY

TABLE 4: COOLING CAPACITIES - 2-1/2 TON (BHP030)

TEMPERATURE AIR ON OUTDOOR COIL			TEMPERATURE OF AIR ON INDOOR COIL								
			1000 CFM				1125 CFM				
			WB °F				WB °F				
			72	67	62	57	72	67	62	57	
85 °F	NET CAP. MBH		34.1	31.5	28.4	29.9	35.4	32.7	29.5	31.0	
	POWER INPUT kW		2.52	2.48	2.44	2.43	2.64	2.58	2.54	2.53	
	Sensible Capacity MBH ¹	Entering Dry Bulb °F	86	23.9	29.8	28.4	29.9	25.7	31.8	29.5	31.0
			83	21.0	26.9	28.4	29.9	22.4	28.5	29.5	31.0
			80	18.1	23.9	27.9	29.6	19.0	25.2	29.2	30.8
			77	15.2	21.0	24.9	26.6	15.7	21.9	25.9	27.5
			74	12.3	18.1	22.0	23.7	12.4	18.5	22.6	24.2
			71	#N/A	15.2	19.1	20.8	#N/A	15.2	19.2	20.9
			68	#N/A	12.3	16.2	17.9	#N/A	11.9	15.9	17.5
95 °F	NET CAP. MBH		32.6	29.4	26.8	28.9	33.7	30.4	27.7	29.8	
	POWER INPUT kW		2.83	2.81	2.71	2.70	2.93	2.91	2.81	2.79	
	Sensible Capacity MBH ¹	Entering Dry Bulb °F	86	22.8	28.2	26.8	28.9	25.0	29.7	27.7	29.8
			83	19.9	25.3	26.8	28.9	21.7	27.5	27.7	29.8
			80	17.0	22.4	26.6	28.3	18.3	24.2	27.5	29.5
			77	14.1	19.5	23.6	25.4	15.0	20.8	24.2	26.2
			74	11.1	16.5	20.7	22.5	11.7	17.5	20.9	22.9
			71	#N/A	13.6	17.8	19.6	#N/A	14.2	17.6	19.6
			68	#N/A	10.7	14.9	16.7	#N/A	10.9	14.3	16.2
105 °F	NET CAP. MBH		30.3	27.2	25.0	26.7	31.5	28.2	26.0	27.7	
	POWER INPUT kW		3.14	3.12	3.04	3.06	3.24	3.22	3.14	3.16	
	Sensible Capacity MBH ¹	Entering Dry Bulb °F	86	21.7	26.6	25.0	26.7	23.9	27.9	26.0	27.7
			83	18.8	24.1	25.0	26.7	20.6	26.3	26.0	27.7
			80	15.9	21.1	25.4	26.3	17.2	22.9	26.2	27.5
			77	13.0	18.2	22.4	23.3	13.9	19.6	22.9	24.2
			74	10.1	15.3	19.5	20.4	10.6	16.3	19.6	20.9
			71	#N/A	12.4	16.6	17.5	#N/A	13.0	16.2	17.6
			68	#N/A	9.5	13.7	14.6	#N/A	9.7	12.9	14.2
115 °F	NET CAP. MBH		28.0	24.9	23.2	24.4	29.3	26.1	24.4	25.6	
	POWER INPUT kW		3.45	3.43	3.37	3.42	3.56	3.54	3.48	3.53	
	Sensible Capacity MBH ¹	Entering Dry Bulb °F	86	20.7	24.9	23.2	24.4	22.8	26.1	24.4	25.6
			83	17.7	22.8	23.2	24.4	19.5	25.0	24.4	25.6
			80	14.8	19.9	24.2	24.2	16.2	21.7	24.8	25.5
			77	11.9	17.0	21.3	21.3	12.8	18.4	21.5	22.2
			74	9.0	14.1	18.3	18.4	9.5	15.1	18.2	18.9
			71	#N/A	11.2	15.4	15.4	#N/A	11.8	14.9	15.5
			68	#N/A	8.3	12.5	12.5	#N/A	8.4	11.6	12.2
125 °F	NET CAP. MBH		25.6	22.7	21.4	22.2	27.2	24.0	22.7	23.5	
	POWER INPUT kW		3.76	3.74	3.70	3.78	3.87	3.85	3.82	3.89	
	Sensible Capacity MBH ¹	Entering Dry Bulb °F	86	19.6	23.3	21.4	22.2	21.7	24.3	22.7	23.5
			83	16.7	21.6	21.4	22.2	18.4	23.8	22.7	23.5
			80	13.7	18.7	23.0	22.1	15.1	20.5	23.5	23.5
			77	10.8	15.8	20.1	19.2	11.7	17.2	20.2	20.2
			74	7.9	12.9	17.1	16.3	8.4	13.9	16.8	16.8
			71	#N/A	10.0	14.2	13.4	#N/A	10.5	13.5	13.5
			68	#N/A	7.1	11.3	10.4	#N/A	7.2	10.2	10.2

1. These capacities are net capacities - indoor fan heat deducted.

 ALL SENSIBLE CAPACITY

TABLE 5: COOLING CAPACITIES - 3 TON (BHP036)

TEMPERATURE AIR ON OUTDOOR COIL			TEMPERATURE OF AIR ON INDOOR COIL								
			1050 CFM				1200 CFM				
			WB °F				WB °F				
			72	67	62	57	72	67	62	57	
85 °F	NET CAP. MBH		41.1	37.5	34.5	34.3	42.4	38.6	35.5	35.3	
	POWER INPUT kW		2.89	2.81	2.73	2.73	3.00	2.91	2.83	2.82	
	Sensible Capacity MBH ¹	Entering Dry Bulb °F	86	25.6	32.3	34.5	34.3	28.2	35.5	35.5	35.3
			83	22.5	29.3	33.5	33.6	24.7	32.0	35.5	35.3
			80	19.5	26.3	31.7	32.2	21.2	28.5	34.5	35.0
			77	16.5	23.2	28.7	29.1	17.7	25.0	31.0	31.5
			74	13.4	20.2	25.7	26.1	14.2	21.6	27.5	28.0
			71	#N/A	17.2	22.6	23.1	#N/A	18.1	24.0	24.5
			68	#N/A	14.1	19.6	20.0	#N/A	14.6	20.5	21.0
95 °F	NET CAP. MBH		38.5	34.9	32.5	32.6	39.4	35.8	33.3	33.4	
	POWER INPUT kW		3.21	3.15	3.05	3.06	3.31	3.25	3.15	3.16	
	Sensible Capacity MBH ¹	Entering Dry Bulb °F	86	25.0	30.9	32.5	32.6	27.5	33.9	33.3	33.4
			83	22.0	27.9	31.9	32.0	24.0	30.4	33.3	33.4
			80	19.0	24.8	30.5	30.6	20.5	26.9	33.0	33.1
			77	15.9	21.8	27.5	27.5	17.0	23.4	29.5	29.6
			74	12.9	18.8	24.4	24.5	13.5	19.9	26.0	26.1
			71	#N/A	15.7	21.4	21.5	#N/A	16.4	22.5	22.6
			68	#N/A	12.7	18.4	18.5	#N/A	12.9	19.0	19.1
105 °F	NET CAP. MBH		35.6	32.1	29.5	30.4	36.4	32.8	30.2	31.1	
	POWER INPUT kW		3.61	3.52	3.44	3.45	3.70	3.61	3.53	3.54	
	Sensible Capacity MBH ¹	Entering Dry Bulb °F	86	23.9	29.4	29.5	30.4	26.2	31.9	30.2	31.1
			83	20.9	26.6	29.2	30.0	22.7	28.9	30.2	31.1
			80	17.9	23.6	27.8	28.6	19.2	25.4	30.0	30.8
			77	14.8	20.5	24.8	25.5	15.7	21.9	26.5	27.3
			74	11.8	17.5	21.8	22.5	12.2	18.4	23.0	23.8
			71	#N/A	14.5	18.7	19.5	#N/A	14.9	19.5	20.3
			68	#N/A	11.4	15.7	16.4	#N/A	11.4	16.0	16.8
115 °F	NET CAP. MBH		32.6	29.3	26.5	28.2	33.3	29.9	27.0	28.8	
	POWER INPUT kW		4.01	3.88	3.83	3.84	4.10	3.97	3.91	3.92	
	Sensible Capacity MBH ¹	Entering Dry Bulb °F	86	22.8	27.8	26.5	28.2	25.0	29.9	27.0	28.8
			83	19.8	25.3	26.5	28.0	21.5	27.4	27.0	28.8
			80	16.8	22.3	25.2	26.5	18.0	23.9	27.0	28.5
			77	13.7	19.2	22.2	23.5	14.5	20.4	23.5	25.0
			74	10.7	16.2	19.1	20.5	11.0	16.9	20.0	21.5
			71	#N/A	13.2	16.1	17.4	#N/A	13.4	16.5	18.0
			68	#N/A	10.1	13.1	14.4	#N/A	9.9	13.0	14.5
125 °F	NET CAP. MBH		29.7	26.4	23.5	26.0	30.2	26.9	23.9	26.4	
	POWER INPUT kW		4.41	4.25	4.21	4.22	4.49	4.33	4.29	4.30	
	Sensible Capacity MBH ¹	Entering Dry Bulb °F	86	21.7	26.3	23.5	26.0	23.7	27.9	23.9	26.4
			83	18.7	24.0	23.8	25.9	20.2	25.9	23.9	26.4
			80	15.7	21.0	22.6	24.5	16.7	22.4	24.1	26.2
			77	12.6	17.9	19.5	21.5	13.2	18.9	20.6	22.7
			74	9.6	14.9	16.5	18.4	9.7	15.4	17.1	19.2
			71	#N/A	11.9	13.5	15.4	#N/A	11.9	13.6	15.7
			#78	#N/A	8.8	10.4	12.4	#N/A	8.4	10.1	12.2

¹. These capacities are net capacities - indoor fan heat deducted.

 ALL SENSIBLE CAPACITY

TABLE 6: COOLING CAPACITIES - 3-1/2 TON (BHP042)

TEMPERATURE AIR ON OUTDOOR COIL			TEMPERATURE OF AIR ON INDOOR COIL								
			1300 CFM				1400 CFM				
			WB °F				WB °F				
			72	67	62	57	72	67	62	57	
85 °F	NET CAP. MBH		48.8	44.5	40.5	40.6	49.2	44.9	40.8	41.0	
	POWER INPUT kW		3.37	3.32	3.21	3.20	3.43	3.38	3.27	3.26	
	Sensible Capacity MBH ¹	Entering Dry Bulb °F	86	31.6	39.4	40.5	40.6	33.0	41.0	40.8	41.0
			83	27.8	35.6	40.1	40.5	28.9	36.9	40.8	41.0
			80	24.0	31.8	38.8	40.2	24.8	32.8	40.1	41.5
			77	20.2	27.9	35.0	36.4	20.7	28.8	36.0	37.4
			74	16.4	24.1	31.2	32.6	16.7	24.7	31.9	33.4
			71	#N/A	20.3	27.4	28.7	#N/A	20.6	27.9	29.3
			68	#N/A	16.5	23.5	24.9	#N/A	16.5	23.8	25.2
95 °F	NET CAP. MBH		45.4	41.5	38.3	38.5	45.7	41.9	38.6	38.8	
	POWER INPUT kW		3.67	3.66	3.54	3.54	3.72	3.71	3.60	3.60	
	Sensible Capacity MBH ¹	Entering Dry Bulb °F	86	30.7	38.2	38.3	38.5	32.0	39.8	38.6	38.8
			83	26.9	34.4	38.1	38.3	27.9	35.7	38.6	38.8
			80	23.0	30.6	37.5	37.9	23.9	31.6	38.8	39.2
			77	19.2	26.8	33.6	34.0	19.8	27.6	34.7	35.1
			74	15.4	23.0	29.8	30.2	15.7	23.5	30.6	31.0
			71	#N/A	19.1	26.0	26.4	#N/A	19.4	26.5	26.9
			68	#N/A	15.3	22.2	22.6	#N/A	15.3	22.4	22.8
105 °F	NET CAP. MBH		41.9	37.7	35.2	35.6	42.1	37.9	35.4	35.7	
	POWER INPUT kW		4.01	3.98	3.89	3.88	4.06	4.03	3.94	3.93	
	Sensible Capacity MBH ¹	Entering Dry Bulb °F	86	28.1	34.5	35.2	35.6	29.4	35.8	35.4	35.7
			83	24.5	31.6	34.8	35.1	25.6	33.0	35.2	35.5
			80	21.0	28.1	33.7	33.8	21.8	29.1	34.9	35.1
			77	17.4	24.6	30.1	30.3	18.0	25.3	31.1	31.2
			74	13.9	21.0	26.6	26.7	14.1	21.5	27.3	27.4
			71	#N/A	17.5	23.0	23.2	#N/A	17.7	23.5	23.6
			68	#N/A	13.9	19.5	19.6	#N/A	13.9	19.7	19.8
115 °F	NET CAP. MBH		38.7	34.2	32.4	32.9	38.8	34.3	32.5	33.0	
	POWER INPUT kW		4.41	4.35	4.28	4.28	4.46	4.40	4.33	4.32	
	Sensible Capacity MBH ¹	Entering Dry Bulb °F	86	26.8	32.5	32.4	32.9	28.1	33.4	32.5	33.0
			83	23.3	30.2	32.1	32.3	24.3	31.5	32.3	32.7
			80	19.7	26.7	31.2	31.0	20.5	27.7	32.4	32.2
			77	16.2	23.1	27.6	27.5	16.7	23.9	28.6	28.4
			74	12.6	19.6	24.1	24.0	12.9	20.1	24.8	24.6
			71	#N/A	16.1	20.6	20.4	#N/A	16.3	20.9	20.8
			68	#N/A	12.5	17.0	16.9	#N/A	12.5	17.1	17.0
125 °F	NET CAP. MBH		35.6	30.7	29.6	30.3	35.5	30.6	29.6	30.2	
	POWER INPUT kW		4.81	4.73	4.68	4.67	4.85	4.77	4.72	4.71	
	Sensible Capacity MBH ¹	Entering Dry Bulb °F	86	25.5	30.4	29.6	30.3	26.8	31.0	29.6	30.2
			83	22.0	28.8	29.4	29.6	23.0	30.1	29.5	29.9
			80	18.5	25.3	28.7	28.3	19.2	26.3	29.8	29.4
			77	14.9	21.7	25.1	24.8	15.4	22.5	26.0	25.6
			74	11.4	18.2	21.6	21.2	11.6	18.6	22.2	21.8
			71	#N/A	14.6	18.1	17.7	#N/A	14.8	18.4	18.0
			68	#N/A	11.1	14.5	14.1	#N/A	11.0	14.6	14.2

1. These capacities are net capacities - indoor fan heat deducted.

 ALL SENSIBLE CAPACITY

TABLE 7: COOLING CAPACITIES - 4 TON (BHP048)

TEMPERATURE AIR ON OUTDOOR COIL			TEMPERATURE OF AIR ON INDOOR COIL								
			1500 CFM				1600 CFM				
			WB °F				WB °F				
			72	67	62	57	72	67	62	57	
85 °F	NET CAP. MBH		54.3	50.4	45.7	48.2	54.9	51.0	46.3	48.8	
	POWER INPUT kW		3.97	3.85	3.75	3.74	4.06	3.94	3.83	3.83	
	Sensible Capacity MBH ¹	Entering Dry Bulb °F	86	35.5	45.1	45.7	48.2	37.2	47.1	46.3	48.8
			83	31.2	40.8	45.3	47.5	32.5	42.4	46.3	48.8
			80	26.8	36.4	43.7	45.2	27.8	37.8	45.3	46.9
			77	22.5	32.0	39.3	40.9	23.2	33.1	40.6	42.3
			74	18.1	27.7	35.0	36.5	18.5	28.4	36.0	37.6
			71	#N/A	23.3	30.6	32.2	#N/A	23.8	31.3	32.9
			68	#N/A	19.0	26.3	27.8	#N/A	19.1	26.6	28.3
95 °F	NET CAP. MBH		52.0	47.4	43.5	46.1	52.3	47.7	43.8	46.4	
	POWER INPUT kW		4.33	4.25	4.17	4.11	4.43	4.35	4.26	4.20	
	Sensible Capacity MBH ¹	Entering Dry Bulb °F	86	34.6	43.5	43.5	46.1	36.1	45.3	43.8	46.4
			83	30.3	39.1	43.1	45.4	31.5	40.6	43.8	46.4
			80	25.9	34.8	42.1	43.2	26.8	36.0	43.6	44.7
			77	21.5	30.4	37.8	38.8	22.1	31.3	38.9	40.0
			74	17.2	26.1	33.4	34.5	17.5	26.6	34.3	35.3
			71	#N/A	21.7	29.1	30.1	#N/A	22.0	29.6	30.7
			68	#N/A	17.3	24.7	25.8	#N/A	17.3	24.9	26.0
105 °F	NET CAP. MBH		48.8	44.2	40.1	43.2	49.0	44.5	40.3	43.5	
	POWER INPUT kW		4.71	4.62	4.52	4.47	4.81	4.71	4.61	4.56	
	Sensible Capacity MBH ¹	Entering Dry Bulb °F	86	32.0	40.2	40.1	43.2	33.5	41.8	40.3	43.5
			83	28.0	36.5	39.7	41.8	29.2	38.0	40.1	42.7
			80	23.9	32.4	39.6	39.3	24.8	33.6	41.0	40.8
			77	19.9	28.4	35.5	35.3	20.5	29.3	36.7	36.4
			74	15.9	24.3	31.5	31.2	16.1	24.9	32.3	32.0
			71	#N/A	20.3	27.4	27.2	#N/A	20.6	28.0	27.7
			68	#N/A	16.2	23.4	23.1	#N/A	16.2	23.6	23.3
115 °F	NET CAP. MBH		45.9	41.4	37.0	40.7	46.1	41.5	37.1	40.8	
	POWER INPUT kW		5.19	5.08	4.96	4.93	5.28	5.17	5.05	5.02	
	Sensible Capacity MBH ¹	Entering Dry Bulb °F	86	31.0	38.7	37.0	40.7	32.5	40.2	37.1	40.8
			83	26.9	35.3	37.0	39.3	28.1	36.8	37.1	40.1
			80	22.9	31.3	38.4	36.9	23.8	32.5	39.9	38.3
			77	18.8	27.2	34.4	32.9	19.4	28.1	35.6	34.0
			74	14.8	23.2	30.4	28.8	15.0	23.8	31.2	29.6
			71	#N/A	19.1	26.3	24.8	#N/A	19.4	26.8	25.3
			68	#N/A	15.1	22.3	20.7	#N/A	15.0	22.5	20.9
125 °F	NET CAP. MBH		43.1	38.5	33.9	38.1	43.2	38.6	34.0	38.2	
	POWER INPUT kW		5.66	5.53	5.40	5.39	5.76	5.63	5.50	5.48	
	Sensible Capacity MBH ¹	Entering Dry Bulb °F	86	29.9	37.3	33.9	38.1	31.4	38.6	34.0	38.2
			83	25.9	34.2	34.2	36.8	27.0	35.7	34.1	37.5
			80	21.8	30.1	37.3	34.5	22.7	31.3	38.8	35.9
			77	17.8	26.1	33.3	30.5	18.3	27.0	34.5	31.5
			74	13.7	22.0	29.3	26.4	14.0	22.6	30.1	27.2
			71	#N/A	18.0	25.2	22.4	#N/A	18.3	25.7	22.8
			68	#N/A	14.0	21.2	18.4	#N/A	13.9	21.4	18.5

¹. These capacities are net capacities - indoor fan heat deducted.

 ALL SENSIBLE CAPACITY

TABLE 8: COOLING CAPACITIES - 5 TON (BHP060)

TEMPERATURE AIR ON OUTDOOR COIL			TEMPERATURE OF AIR ON INDOOR COIL								
			1600 CFM				2000 CFM				
			WB °F				WB °F				
			72	67	62	57	72	67	62	57	
85 °F	NET CAP. MBH		64.0	58.5	53.4	53.1	64.5	59.0	53.8	53.6	
	POWER INPUT kW		4.62	4.55	4.46	4.31	5.08	5.00	4.90	4.74	
	Sensible Capacity MBH ¹	Entering Dry Bulb °F	86	39.3	48.7	53.4	53.1	44.8	55.1	53.8	53.6
			83	34.6	44.1	52.7	53.1	38.8	49.2	53.8	53.6
			80	30.0	39.4	48.0	52.3	32.9	43.2	52.6	53.6
			77	25.3	34.8	43.3	47.6	26.9	37.2	46.6	47.6
			74	20.7	30.1	38.7	42.9	20.9	31.3	40.7	41.6
			71	--	25.4	34.0	38.3	--	25.3	34.7	35.7
			68	--	20.8	29.3	33.6	--	19.3	28.8	29.7
95 °F	NET CAP. MBH		61.1	55.7	50.8	50.2	60.5	55.1	50.3	49.7	
	POWER INPUT kW		5.08	5.01	4.89	4.74	5.59	5.51	5.37	5.22	
	Sensible Capacity MBH ¹	Entering Dry Bulb °F	86	38.1	47.4	50.8	50.2	43.4	53.5	50.3	49.7
			83	33.5	42.8	50.8	50.2	37.4	47.5	50.3	49.7
			80	28.8	38.1	46.7	49.4	31.4	41.6	50.3	49.7
			77	24.1	33.4	42.0	44.7	25.5	35.6	44.4	43.7
			74	19.5	28.8	37.4	40.1	19.5	29.7	38.4	37.8
			71	--	24.1	32.7	35.4	--	23.7	32.4	31.8
			68	--	19.4	28.0	30.7	--	17.7	26.5	25.8
105 °F	NET CAP. MBH		56.9	51.2	46.8	47.2	56.3	50.7	46.3	46.7	
	POWER INPUT kW		5.64	5.52	5.37	5.28	6.17	6.04	5.88	5.77	
	Sensible Capacity MBH ¹	Entering Dry Bulb °F	86	36.7	45.7	46.8	47.2	41.9	49.9	46.3	46.7
			83	32.0	41.1	46.8	47.2	35.9	45.9	46.3	46.7
			80	27.3	36.4	46.7	46.1	30.0	39.9	46.3	46.7
			77	22.7	31.7	42.0	41.5	24.0	34.0	40.3	40.7
			74	18.0	27.1	37.3	36.8	18.0	28.0	34.4	34.8
			71	--	22.4	32.7	32.1	--	22.0	28.4	28.8
			68	--	17.7	28.0	27.5	--	16.1	22.4	22.8
115 °F	NET CAP. MBH		52.8	46.8	42.7	44.2	52.2	46.2	42.3	43.7	
	POWER INPUT kW		6.20	6.03	5.86	5.81	6.76	6.57	6.38	6.33	
	Sensible Capacity MBH ¹	Entering Dry Bulb °F	86	35.2	44.1	42.7	44.2	40.4	46.2	42.3	43.7
			83	30.5	39.4	42.7	44.2	34.5	44.2	42.3	43.7
			80	25.9	34.7	46.6	42.8	28.5	38.3	42.3	43.7
			77	21.2	30.1	42.0	38.2	22.5	32.3	36.3	37.7
			74	16.5	25.4	37.3	33.5	16.6	26.3	30.3	31.8
			71	--	20.7	32.6	28.8	--	20.4	24.4	25.8
			68	--	16.1	28.0	24.2	--	14.4	18.4	19.8
125 °F	NET CAP. MBH		48.7	42.3	38.7	41.2	48.0	41.8	38.2	40.7	
	POWER INPUT kW		6.77	6.54	6.34	6.34	7.34	7.10	6.89	6.88	
	Sensible Capacity MBH ¹	Entering Dry Bulb °F	86	33.7	42.4	38.7	41.2	39.0	42.6	38.2	40.7
			83	29.1	37.7	38.7	41.2	33.0	42.5	38.2	40.7
			80	24.4	33.0	46.6	39.5	27.0	36.6	38.2	40.7
			77	19.7	28.4	41.9	34.9	21.1	30.6	32.3	34.7
			74	15.1	23.7	37.3	30.2	15.1	24.7	26.3	28.7
			71	--	19.0	32.6	25.5	--	18.7	20.3	22.8
			68	--	14.4	27.9	20.9	--	12.7	14.4	16.8

1. These capacities are net capacities - indoor fan heat deducted.



ALL SENSIBLE CAPACITY

TABLE 9: HEATING CAPACITIES - 2 TON (BHP024)

CFM	RETURN AIR °F	CAP ¹ & KW	OUTDOOR AIR TEMPERATURE, °F (72% RH)							
			-10	0	10	20	30	40	50	60
600	55	MBH	10.216	11.748	13.601	15.843	18.554	21.834	25.801	30.601
		KW	1.214	1.307	1.401	1.494	1.588	1.681	1.775	1.868
	70	MBH	7.317	8.849	10.702	12.944	15.655	18.935	22.902	27.702
		KW	1.363	1.456	1.550	1.643	1.737	1.830	1.924	2.017
	80	MBH	7.205	8.737	10.590	12.832	15.543	18.823	22.790	27.590
		KW	1.423	1.516	1.610	1.703	1.797	1.890	1.984	2.077
800	55	MBH	10.206	11.738	13.591	15.833	18.544	21.824	25.791	30.591
		KW	1.227	1.320	1.414	1.507	1.601	1.694	1.788	1.881
	70	MBH	7.307	8.839	10.692	12.934	15.645	18.925	22.892	27.692
		KW	1.376	1.469	1.563	1.656	1.750	1.843	1.937	2.030
	80	MBH	7.195	8.727	10.580	12.822	15.533	18.813	22.780	27.580
		KW	1.436	1.529	1.623	1.716	1.810	1.903	1.997	2.090
1000	55	MBH	11.377	12.909	14.762	17.004	19.715	22.995	26.962	31.762
		KW	1.339	1.432	1.526	1.619	1.713	1.806	1.900	1.993
	70	MBH	8.478	10.010	11.863	14.105	16.816	20.096	24.063	28.863
		KW	1.488	1.581	1.675	1.768	1.862	1.955	2.049	2.142
	80	MBH	8.366	9.898	11.751	13.993	16.704	19.984	23.951	28.751
		KW	1.548	1.641	1.735	1.828	1.922	2.015	2.109	2.202

¹. These capacities are net capacities - the indoor motor heat has been added. These power inputs are total power inputs - the indoor motor watts have been added.

TABLE 10: HEATING CAPACITIES - 2-1/2 TON (BHP030)

CFM	RETURN AIR °F	CAP ¹ & KW	OUTDOOR AIR TEMPERATURE, °F (72% RH)							
			-10	0	10	20	30	40	50	60
750	55	MBH	10.876	12.808	15.078	17.744	20.877	24.556	28.879	33.958
		KW	1.847	1.917	1.987	2.057	2.127	2.198	2.268	2.338
	70	MBH	10.046	11.978	14.248	16.914	20.047	23.726	28.049	33.128
		KW	2.135	2.205	2.275	2.345	2.415	2.486	2.556	2.626
	80	MBH	9.054	10.986	13.256	15.922	19.055	22.734	27.057	32.136
		KW	2.377	2.447	2.517	2.587	2.657	2.728	2.798	2.868
1000	55	MBH	11.886	13.818	16.088	18.754	21.887	25.566	29.889	34.968
		KW	1.731	1.801	1.871	1.941	2.011	2.082	2.152	2.222
	70	MBH	11.056	12.988	15.258	17.924	21.057	24.736	29.059	34.138
		KW	2.019	2.089	2.159	2.229	2.299	2.370	2.440	2.510
	80	MBH	10.064	11.996	14.266	16.932	20.065	23.744	28.067	33.146
		KW	2.261	2.331	2.401	2.471	2.541	2.612	2.682	2.752
1250	55	MBH	13.978	15.910	18.180	20.846	23.979	27.658	31.981	37.060
		KW	1.881	1.951	2.021	2.091	2.161	2.232	2.302	2.372
	70	MBH	13.148	15.080	17.350	20.016	23.149	26.828	31.151	36.230
		KW	2.169	2.239	2.309	2.379	2.449	2.520	2.590	2.660
	80	MBH	12.156	14.088	16.358	19.024	22.157	25.836	30.159	35.238
		KW	2.411	2.481	2.551	2.621	2.691	2.762	2.832	2.902

¹. These capacities are net capacities - the indoor motor heat has been added. These power inputs are total power inputs - the indoor motor watts have been added.

TABLE 11: HEATING CAPACITIES - 3 TON (BHP036)

CFM	RETURN AIR °F	CAP ¹ & KW	OUTDOOR AIR TEMPERATURE, °F (72% RH)							
			-10	0	10	20	30	40	50	60
900	55	MBH	10.597	12.792	15.448	18.660	22.545	27.244	32.929	39.804
		KW	1.791	1.898	2.005	2.112	2.219	2.326	2.433	2.540
	70	MBH	9.420	11.615	14.271	17.483	21.368	26.067	31.752	38.627
		KW	2.198	2.305	2.412	2.519	2.626	2.733	2.840	2.947
	80	MBH	7.543	9.738	12.394	15.606	19.491	24.190	29.875	36.750
		KW	2.476	2.583	2.690	2.797	2.904	3.011	3.118	3.225
1200	55	MBH	11.652	13.847	16.503	19.715	23.600	28.299	33.984	40.859
		KW	1.825	1.932	2.039	2.146	2.253	2.360	2.467	2.574
	70	MBH	10.475	12.670	15.326	18.538	22.423	27.122	32.807	39.682
		KW	2.232	2.339	2.446	2.553	2.660	2.767	2.874	2.981
	80	MBH	8.598	10.793	13.449	16.661	20.546	25.245	30.930	37.805
		KW	2.510	2.617	2.724	2.831	2.938	3.045	3.152	3.259
1500	55	MBH	12.282	14.477	17.133	20.345	24.230	28.929	34.614	41.489
		KW	1.779	1.886	1.993	2.100	2.207	2.314	2.421	2.528
	70	MBH	11.105	13.300	15.956	19.168	23.053	27.752	33.437	40.312
		KW	2.186	2.293	2.400	2.507	2.614	2.721	2.828	2.935
	80	MBH	9.228	11.423	14.079	17.291	21.176	25.875	31.560	38.435
		KW	2.464	2.571	2.678	2.785	2.892	2.999	3.106	3.213

¹. These capacities are net capacities - the indoor motor heat has been added. These power inputs are total power inputs - the indoor motor watts have been added.

TABLE 12: HEATING CAPACITIES - 3-1/2 TON (BHP042)

CFM	RETURN AIR °F	CAP ¹ & KW	OUTDOOR AIR TEMPERATURE, °F (72% RH)							
			-10	0	10	20	30	40	50	60
1050	55	MBH	15.404	17.988	20.968	24.404	28.369	32.941	38.215	44.298
		KW	2.410	2.505	2.599	2.694	2.789	2.883	2.978	3.073
	70	MBH	14.342	16.926	19.906	23.342	27.307	31.879	37.153	43.236
		KW	2.835	2.930	3.024	3.119	3.214	3.308	3.403	3.498
	80	MBH	13.669	16.253	19.233	22.669	26.634	31.206	36.480	42.563
		KW	3.143	3.238	3.332	3.427	3.522	3.616	3.711	3.806
1400	55	MBH	17.901	20.485	23.465	26.901	30.866	35.438	40.712	46.795
		KW	2.419	2.514	2.608	2.703	2.798	2.892	2.987	3.082
	70	MBH	16.839	19.423	22.403	25.839	29.804	34.376	39.650	45.733
		KW	2.844	2.939	3.033	3.128	3.223	3.317	3.412	3.507
	80	MBH	16.166	18.750	21.730	25.166	29.131	33.703	38.977	45.060
		KW	3.152	3.247	3.341	3.436	3.531	3.625	3.720	3.815
1750	55	MBH	18.901	21.485	24.465	27.901	31.866	36.438	41.712	47.795
		KW	2.463	2.558	2.652	2.747	2.842	2.936	3.031	3.126
	70	MBH	17.839	20.423	23.403	26.839	30.804	35.376	40.650	46.733
		KW	2.888	2.983	3.077	3.172	3.267	3.361	3.456	3.551
	80	MBH	17.166	19.750	22.730	26.166	30.131	34.703	39.977	46.060
		KW	3.196	3.291	3.385	3.480	3.575	3.669	3.764	3.859

¹. These capacities are net capacities - the indoor motor heat has been added. These power inputs are total power inputs - the indoor motor watts have been added.

TABLE 13: HEATING CAPACITIES - 4 TON (BHP048)

CFM	RETURN AIR °F	CAP ¹ & KW	OUTDOOR AIR TEMPERATURE, °F (72% RH)							
			-10	0	10	20	30	40	50	60
1200	55	MBH	13.911	17.096	21.021	25.859	31.821	39.170	48.226	59.388
		KW	2.342	2.568	2.795	3.022	3.249	3.476	3.703	3.930
	70	MBH	11.264	14.449	18.374	23.212	29.174	36.523	45.579	56.741
		KW	2.726	2.952	3.179	3.406	3.633	3.860	4.087	4.314
	80	MBH	9.676	12.861	16.786	21.624	27.586	34.935	43.991	55.153
		KW	3.067	3.293	3.520	3.747	3.974	4.201	4.428	4.655
1600	55	MBH	16.349	19.534	23.459	28.297	34.259	41.608	50.664	61.826
		KW	2.408	2.634	2.861	3.088	3.315	3.542	3.769	3.996
	70	MBH	13.702	16.887	20.812	25.650	31.612	38.961	48.017	59.179
		KW	2.792	3.018	3.245	3.472	3.699	3.926	4.153	4.380
	80	MBH	12.114	15.299	19.224	24.062	30.024	37.373	46.429	57.591
		KW	3.133	3.359	3.586	3.813	4.040	4.267	4.494	4.721
2000	55	MBH	17.629	20.814	24.739	29.577	35.539	42.888	51.944	63.106
		KW	2.502	2.728	2.955	3.182	3.409	3.636	3.863	4.090
	70	MBH	14.982	18.167	22.092	26.930	32.892	40.241	49.297	60.459
		KW	2.886	3.112	3.339	3.566	3.793	4.020	4.247	4.474
	80	MBH	13.394	16.579	20.504	25.342	31.304	38.653	47.709	58.871
		KW	3.227	3.453	3.680	3.907	4.134	4.361	4.588	4.815

¹. These capacities are net capacities - the indoor motor heat has been added. These power inputs are total power inputs - the indoor motor watts have been added.

TABLE 14: HEATING CAPACITIES - 5 TON (BHP060)

CFM	RETURN AIR °F	CAP ¹ & KW	OUTDOOR AIR TEMPERATURE, °F (72% RH)							
			-10	0	10	20	30	40	50	60
1950	55	MBH	16.136	19.904	24.617	30.513	37.889	47.115	58.657	73.095
		KW	2.403	2.771	3.140	3.509	3.877	4.246	4.615	4.983
	70	MBH	15.014	18.782	23.495	29.391	36.767	45.993	57.535	71.973
		KW	2.967	3.335	3.704	4.073	4.441	4.810	5.179	5.547
	80	MBH	11.066	14.834	19.547	25.443	32.819	42.045	53.587	68.025
		KW	3.368	3.736	4.105	4.474	4.842	5.211	5.580	5.948
2000	55	MBH	16.054	19.822	24.535	30.431	37.807	47.033	58.575	73.013
		KW	2.411	2.779	3.148	3.517	3.885	4.254	4.623	4.991
	70	MBH	14.932	18.700	23.413	29.309	36.685	45.911	57.453	71.891
		KW	2.975	3.343	3.712	4.081	4.449	4.818	5.187	5.555
	80	MBH	10.984	14.752	19.465	25.361	32.737	41.963	53.505	67.943
		KW	3.376	3.744	4.113	4.482	4.850	5.219	5.588	5.956

¹. These capacities are net capacities - the indoor motor heat has been added. These power inputs are total power inputs - the indoor motor watts have been added.

TABLE 15: SIDE & BOTTOM SUPPLY AIR BLOWER PERFORMANCE (208/230/460 VOLT¹)

MODEL NO. BHP	MOTOR SPEED SETTING	UNIT AIRFLOW	EXTERNAL STATIC PRESSURE - IWG				
			0.15	0.30	0.50	0.70	0.90
			WATTS				
B1HP024	Cooling TB2-A, Heating TB2-A, Electric Heat	800 CFM	91	125	161	206	240
B1HP024	Cooling TB2-B, Heating TB2-B	900 CFM	118	148	199	243	285
B1HP030	Cooling TB2-A, Heating TB2-A, Electric Heat	1000 CFM	280	321	389	449	500
B1HP030	Cooling TB2-B, Heating TB2-B	1125 CFM	356	413	490	557	620
B1HP036	Cooling TB2-A, Heating TB2-A	1050 CFM	209	261	319	372	438
B1HP036	Cooling TB2-B, Heating TB2-B, Electric Heat	1200 CFM	273	324	392	480	541
B1HP042	Electric Heat	1225 CFM	306	341	412	494	577
B1HP042	Cooling TB2-A, Heating TB2-A	1300 CFM	338	395	470	551	640
B1HP042	Cooling TB2-B, Heating TB2-B	1400 CFM	393	466	544	642	734
B1HP048	Heating TB2-A	1400 CFM	377	427	504	597	683
B1HP048	Cooling TB2-A	1500 CFM	455	516	601	703	788
B1HP048	Cooling TB2-B, Heating TB2-B, Electric Heat	1600 CFM	530	608	707	800	873
B1HP060	Cooling TB2-A	1600 CFM	385	478	489	596	703
B1HP060	Heating TB2-A	1900 CFM	400	493	593	700	807
B1HP060	Cooling TB2-B	2000 CFM	590	717	833	940	1047

¹. All units are factory set to TB2-A.

NOTE: Above data includes allowances for a dry indoor coil and no filters. For additional pressure drops, refer to the "Additional Static Pressure Resistance" table.

TABLE 16: ADDITIONAL STATIC RESISTANCE

DESCRIPTION	RESISTANCE, IWG															
	CFM															
	500	600	700	800	900	1,000	1,100	1,200	1,300	1,400	1,500	1,600	1,700	1,800	1,900	2,000
Wet Indoor Coil	0.01	0.01	0.01	0.02	0.01	0.02	0.03	0.04	0.04	0.03	0.04	0.04	0.05	0.05	0.06	0.07
Economizer	0.00	0.00	0.00	0.01	0.01	0.01	0.01	0.02	0.03	0.04	0.05	0.06	0.07	0.07	0.08	0.08
Filter/Frame Kit	0.01	0.02	0.02	0.02	0.02	0.02	0.03	0.03	0.03	0.03	0.04	0.05	0.05	0.06	0.06	0.07
Electric Heat	0.02	0.03	0.03	0.03	0.04	0.04	0.05	0.06	0.07	0.08	0.09	0.10	0.01	0.11	0.11	0.12

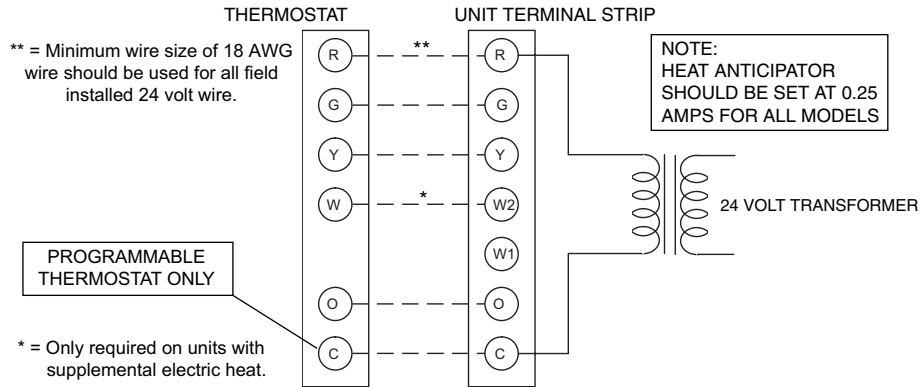

CAUTION: Label all wires prior to disconnection when servicing controls. Wiring errors can cause improper and dangerous operation. Verify proper operation after servicing.

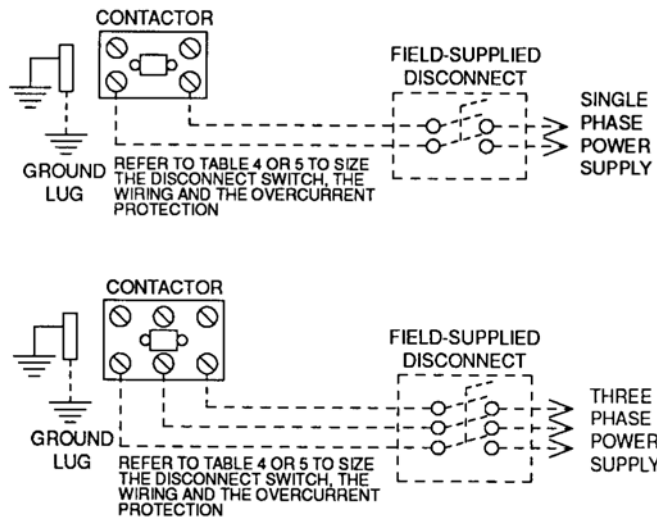

FIGURE 2 - FIELD WIRING DIAGRAM

TABLE 17: ELECTRICAL DATA (BASIC UNIT)

MODEL BHP	POWER SUPPLY	VOLTAGE LIMITATIONS ¹		COMPRESSOR		OUTDOOR FAN MOTOR, FLA	SUPPLY AIR BLOWER MOTOR, FLA	MINIMUM CIRCUIT AMPACITY	MAX FUSE SIZE, AMPS ²	MAX. HACR BREAKER SIZE, AMPS	UNIT POWER FACTOR	TRANSFORMER SIZE (VA)
		MIN.	MAX.	RLA	LRA							
024	208/230-1-60	187	253	9.3	57.0	1.1	5.0	17.7	25	25	0.96	40
030	208/230-1-60	187	253	15.0	72.5	1.1	5.0	24.9	30	30	0.96	40
	208/230-3-60	187	253	10.0	63.0	1.1	5.0	18.6	25	25	0.96	75
	460-3-60	414	504	5.0	31.0	0.6	5.0	11.9	15	15	0.96	75
036	208/230-1-60	187	253	17.2	94.0	1.1	7.3	29.9	35	35	0.96	40
	208/230-3-60	187	253	11.4	78.0	1.1	7.3	22.7	30	30	0.96	75
	460-3-60	414	504	5.7	40.0	0.6	7.3	15.4	20	20	0.96	75
042	208/230-1-60	187	253	20.0	104.0	1.1	7.3	33.4	40	40	0.96	40
	208/230-3-60	187	253	13.9	88.0	1.1	7.3	25.8	30	30	0.96	75
	460-3-60	414	504	6.4	44.0	0.6	7.3	16.1	20	20	0.96	75
048	208/230-1-60	187	253	23.4	126.0	1.5	7.3	38.1	45	45	0.96	40
	208/230-3-60	187	253	13.0	93.0	1.5	7.3	25.1	30	30	0.96	75
	460-3-60	414	504	6.4	46.5	0.8	7.3	16.3	20	20	0.96	75
060	208/230-1-60	187	253	25	150	2.3	9.1	42.7	50	50	0.96	40
	208/230-3-60	187	253	17.3	130	2.3	9.1	33	40	40	0.96	75
	460-3-60	414	504	8.4	70	1.3	9.1	21.1	25	25	0.96	75
	575-3-60	540	630	7.1	53	1.3	9.1	19.7	25	25	0.96	75

1. Rated in accordance with ARI Standard 100, utilization range "A".

2. Dual element, time delay type.

ELECTRIC HEAT CORRECTION FACTORS	NOMINAL VOLTAGE	VOLTAGE	KW CAP. MULTIPLIER
	240	208	0.75
		230	0.92
	480	460	0.92
600	575	0.92	

TABLE 18: ELECTRICAL DATA (13 SEER HEAT PUMP / ELECTRIC HEAT)

MODEL BHP	POWER SUPPLY	COMPRESSOR		COND FAN MOTOR FLA	SUPPLY AIR BLOWER MOTOR FLA	ELECTRIC HEAT ACCESSORY			MINIMUM CIRCUIT AMPACITY	MAX. FUSE/ SIZE, ¹ AMPS	MAX HACR ² BREAKER SIZE
		RLA	LRA			MODEL NO.	KW	TOTAL AMPS			
024	208/230-1-60	9.3	57.0	1.1	5.0	2NH04500506	3.8 / 5.0 *	18.1 / 20.8	40.3 / 43.8	45 / 45	45 / 45
						2NH04500706	5.6 / 7.5 *	27.1 / 31.3	51.6 / 56.8	60 / 60	60 / 60
						2NH04501006	7.5 / 10.0 *	36.1 / 41.7	62.9 / 69.8	70 / 70	70 / 70
030	208/230-1-60	15.0	72.5	1.1	5.0	2NH04500506	3.8 / 5.0 *	18.1 / 20.8	47.4 / 50.9	50 / 60	50 / 60
						2NH04500706	5.6 / 7.5 *	27.3 / 31.3	58.7 / 63.9	60 / 70	60 / 70
						2NH04501006	7.5 / 10.0 *	36.1 / 41.7	70.0 / 76.9	70 / 80	70 / 80
036	208/230-1-60	17.2	94.0	1.1	7.3	2NH04500506	3.8 / 5.0 *	18.1 / 20.8	52.5 / 55.9	60 / 60	60 / 60
						2NH04500706	5.6 / 7.5 *	27.1 / 31.3	63.8 / 69.0	70 / 70	70 / 70
						2NH04501006	7.5 / 10.0 *	36.1 / 41.7	75.0 / 82.0	80 / 90	80 / 90
042	208/230-1-60	20.0	104.0	1.1	7.3	2NP04501006	7.5 / 10.0 *	36.1 / 41.7	78.5 / 85.5	80 / 90	80 / 90
						2NP04501506	11.3 / 15.0 *	54.2 / 62.5	101.1 / 111.5	110 / 125	110 / 125
						2NP04501006	7.5 / 10.0 *	36.1 / 41.7	83.2 / 90.1	90 / 100	90 / 100
048	208/230-1-60	23.4	126.0	1.5	7.3	2NP04501506	11.3 / 15.0 *	54.2 / 62.5	105.8 / 116.2	110 / 125	110 / 125
						2NP04502006	15.0 / 20.0 *	72.2 / 83.3	128.3 / 142.2	150 / 150	150 / 150
						2NP04502506	18.8 / 25.0 *	90.3 / 104.2	150.9 / 168.3	175 / 175	175 / 175
060	208/230-1-60	25	150	2.3	9.1	2NP04501006	7.5 / 10.0 *	36.1 / 41.7	87.7 / 94.7	100 / 100	100 / 100
						2NP04501506	11.3 / 15.0 *	54.2 / 62.5	110.6 / 120.8	125 / 125	125 / 125
						2NP04502006	15.0 / 20.0 *	72.2 / 83.3	132.8 / 146.8	150 / 150	150 / 150
030	208/230-3-60	10.0	63.0	1.1	5.0	2NH04501025	7.5 / 10.0 *	20.8 / 24.1	44.7 / 48.7	45 / 50	45 / 50
						2NH04501525	11.3 / 15.0 *	31.3 / 36.1	57.7 / 63.7	60 / 70	60 / 70
						2NH04501025	7.5 / 10.0 *	20.8 / 24.1	48.7 / 52.7	50 / 60	50 / 60
036	208/230-3-60	11.4	78.0	1.1	7.3	2NH04501025	7.5 / 10.0 *	20.8 / 24.1	48.7 / 52.7	50 / 60	50 / 60
						2NH04501525	11.3 / 15.0 *	31.3 / 36.1	61.7 / 67.8	70 / 70	70 / 70
						2NP04501025	7.5 / 10.0 *	20.8 / 24.1	51.8 / 55.8	60 / 60	60 / 60
042	208/230-3-60	13.9	88.0	1.1	7.3	2NP04501525	11.3 / 15.0 *	31.3 / 36.1	64.9 / 70.9	70 / 80	70 / 80
						2NP04501025	7.5 / 10.0 *	20.8 / 24.1	51.1 / 55.1	60 / 60	60 / 60
						2NP04501525	11.3 / 15.0 *	31.3 / 36.1	64.1 / 70.2	70 / 80	70 / 80
048	208/230-3-60	13.0	93.0	1.5	7.3	2NP04502025	15.0 / 20.0 *	41.7 / 48.1	77.2 / 85.2	80 / 90	80 / 90
						2NP04502525	18.8 / 25.0 *	52.1 / 60.1	90.2 / 100.2	100 / 110	100 / 110
						2NP04501025	7.5 / 10.0 *	20.8 / 24.1	59.1 / 63.1	70 / 70	70 / 70
060	208/230-3-60	17.3	130	2.3	9.1	2NP04501525	11.3 / 15.0 *	31.3 / 36.1	72.2 / 78.1	80 / 80	80 / 80
						2NP04502025	15.0 / 20.0 *	41.7 / 48.1	85.1 / 93.2	90 / 100	90 / 100
						2NP04502525	18.8 / 25.0 *	52.1 / 60.1	98.3 / 108.2	100 / 110	100 / 110
030	460-3-60	5.0	31.0	0.6	5.0	2NH04501046	10.0 **	12.0	27.5	30	30
						2NH04501546	15.0 **	18.0	35.4	40	40
036	460-3-60	5.7	40.0	0.6	7.3	2NH04501046	10.0 **	12.0	30.7	35	35
						2NH04501546	15.0 **	18.0	38.6	40	40
042	460-3-60	6.4	44.0	0.6	7.3	2NP04501046	10.0 **	12.0	31.6	35	35
						2NP04501546	15.0 **	18.0	39.4	40	40
048	460-3-60	6.4	46.5	0.8	7.3	2NP04501046	10.0 **	12.0	31.8	35	35
						2NP04501546	15.0 **	18.0	39.6	40	40
						2NH04502046	20.0 **	24.1	47.5	50	50
						2NH04502546	25.0 **	30.1	55.3	60	60
060	460-3-60	8.4	70	1.3	9.1	2NP04501046	10.0 **	12.0	36.1	40	40
						2NP04501546	15.0 **	18.0	43.6	45	45
						2NH04502046	20.0 **	24.1	51.1	60	60
						2NH04502546	25.0 **	30.1	58.7	60	60
060	575-3-60	7.1	53	1.3	9.5	2NP04501058	10.0 ***	10.0	32.3	35	35
						2NP04501558	15.0 ***	15.1	38.6	40	40
						2NH04502058	20.0 ***	20.1	44.8	45	45
						2NH04502558	25.0 ***	25.1	51.0	60	60

1. Dual element, time delay type.

2. Standard circuit breakers may be used in Canada and on applications over 60 amps where the heaters are separately fused.

* KW listed is for 240 volts, use Table 17 for 208 or 230 volts.

** KW listed is for 480 volts, use Table 17 for 460 volts.

*** KW listed is for 600 volts, use Table 17 for 575 volts.

TABLE 19: APPLICATION DATA

MODEL		BHP					
		024	030	036	042	048	060
MINIMUM AIR FLOW (CFM)	COOLING	800	1000	1050	1300	1500	1500
	HEATING	800	1000	1050	1400	1400	1500
MAXIMUM AIR FLOW (CFM)	COOLING	900	1125	1200	1400	1600	2050
	HEATING	900	1125	1200	1500	1600	2050
MINIMUM OPERATING TEMPERATURE IN COOLING MODE (AMBIENT, °F)		45	45	45	45	45	45
MINIMUM MIXED AIR IN COOLING MODE (RETURN AIR, DB °F/WB °F)		68 / 57	68 / 57	68 / 57	68 / 57	68 / 57	68 / 57
MINIMUM MIXED AIR IN HEATING MODE (RETURN AIR, °F)		55	55	55	55	55	55

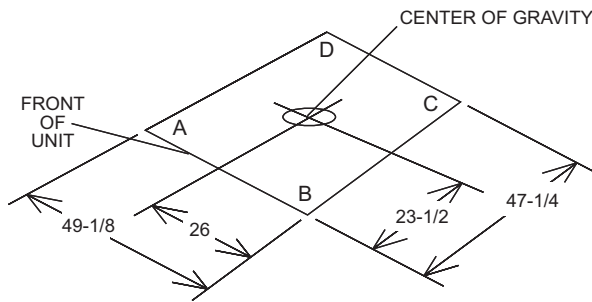

B1HP UNIT SIZE	SHIPPING WEIGHT	OPERATING WEIGHT	CORNER WEIGHTS			
			A	B	C	D
024	356	351	97	93	81	84
030	353	348	96	93	81	84
036	388	383	106	102	89	92
042	440	435	120	115	101	104
048	485	480	132	127	111	115
060	495	490	135	130	113	117

FIGURE 3 - CENTER OF GRAVITY AND WEIGHTS

CLEARANCES

UNIT CLEARANCES (MINIMUM)	
Front	12"
Back	0"
Left Side (Filter Access)	24"
Right Side	24"
Below Unit ¹	0"
Above Unit ²	36" (For Condenser Air Discharge)

- Units may be installed on combustible floors made from wood or class A, B or C roof covering.
- Units must be installed outdoors. Overhanging structures or shrubs should not obstruct outdoor air discharge outlet.

NOTE: FOR UNITS APPLIED WITH A ROOF CURB, THE MINIMUM CLEARANCE MAY BE REDUCED FROM 1 INCH TO 1/2 INCH BETWEEN COMBUSTIBLE ROOF CURB MATERIAL AND THE SUPPLY DUCT.

MINIMUM CLEARANCE OF 1" ALL SIDES FOR THE FIRST 3' OF DUCT FOR 20 & 25 kW. ZERO INCHES THEREAFTER, FOR ALL OTHER HEATERS, ZERO INCH CLEARANCE ALL SIDES FOR ENTIRE LENGTH OF DUCT.

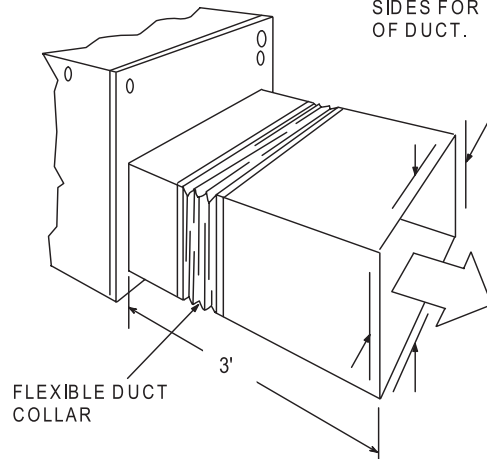
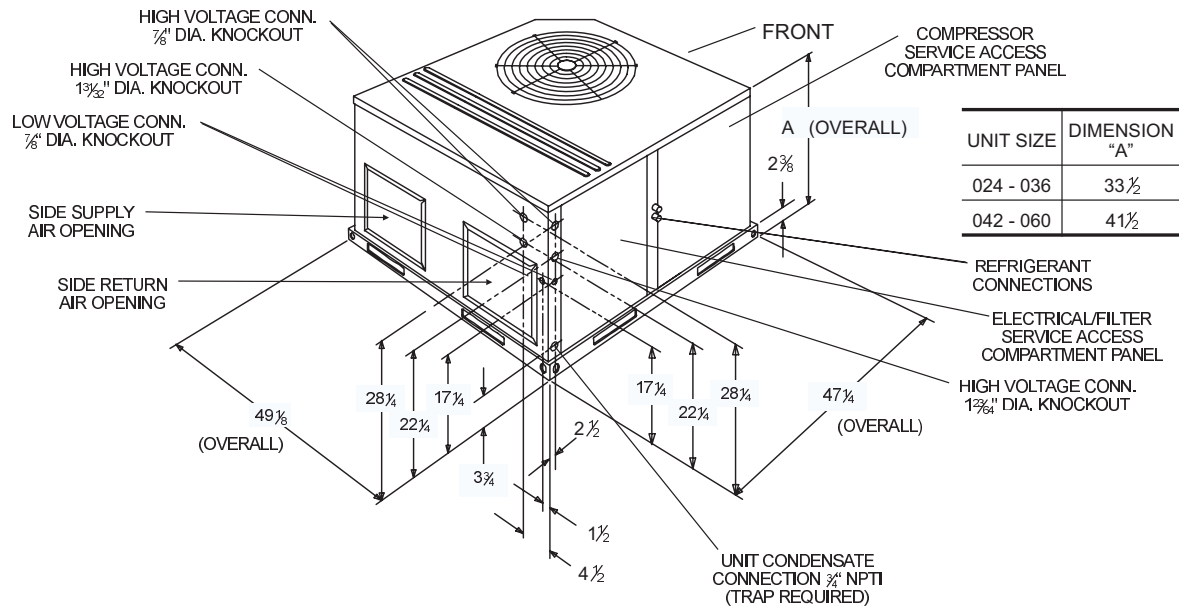

FIGURE 4 - UNIT CLEARANCES



UNIT SIZE	DIMENSION "A"
024 - 036	33 1/2
042 - 060	41 1/2

All dimensions are in inches. They are subject to change without notice. Certified dimensions will be provided upon request.

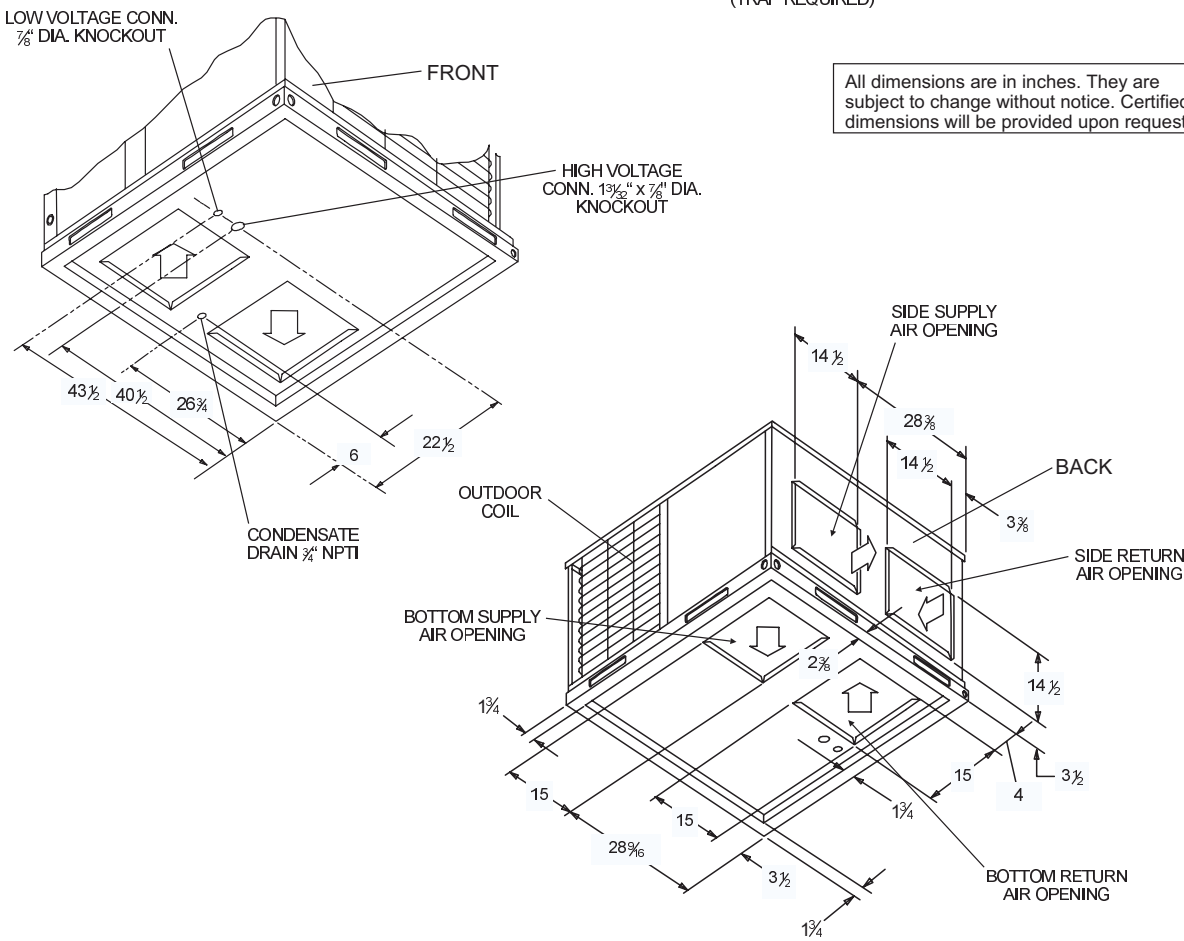
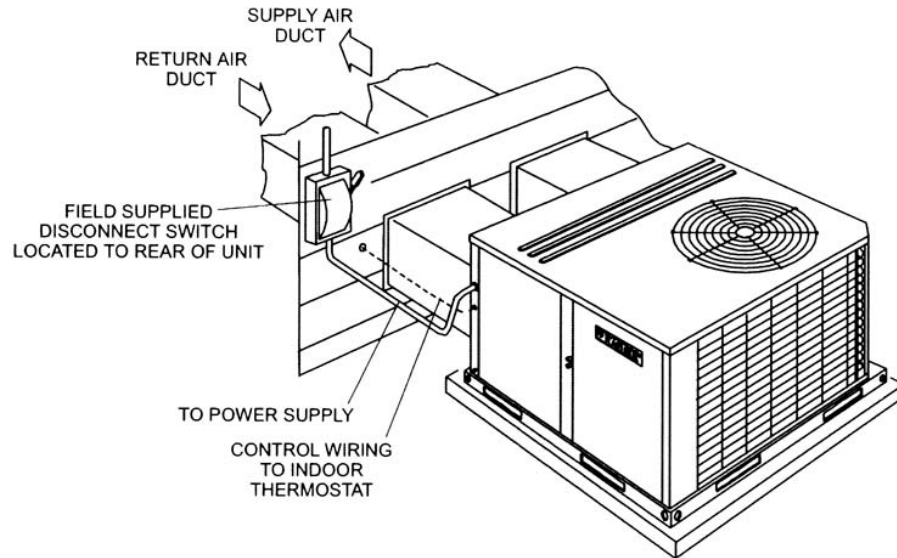

FIGURE 5 - UNIT DIMENSIONS

TYPICAL SLAB ON GROUND INSTALLATION



TYPICAL ROOF CURB INSTALLATION

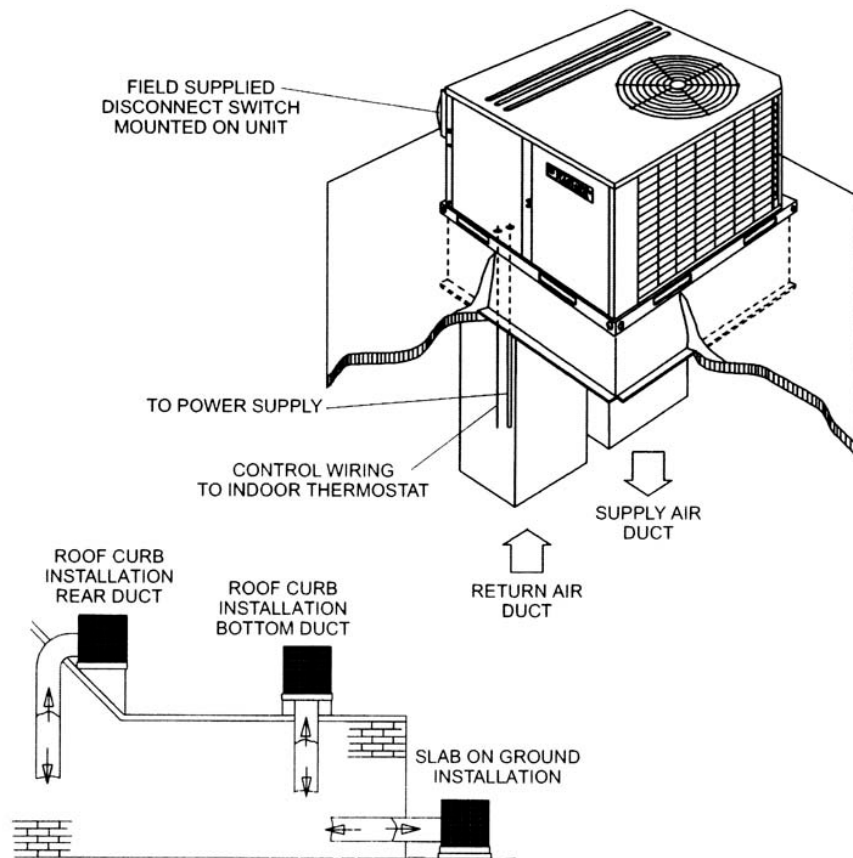
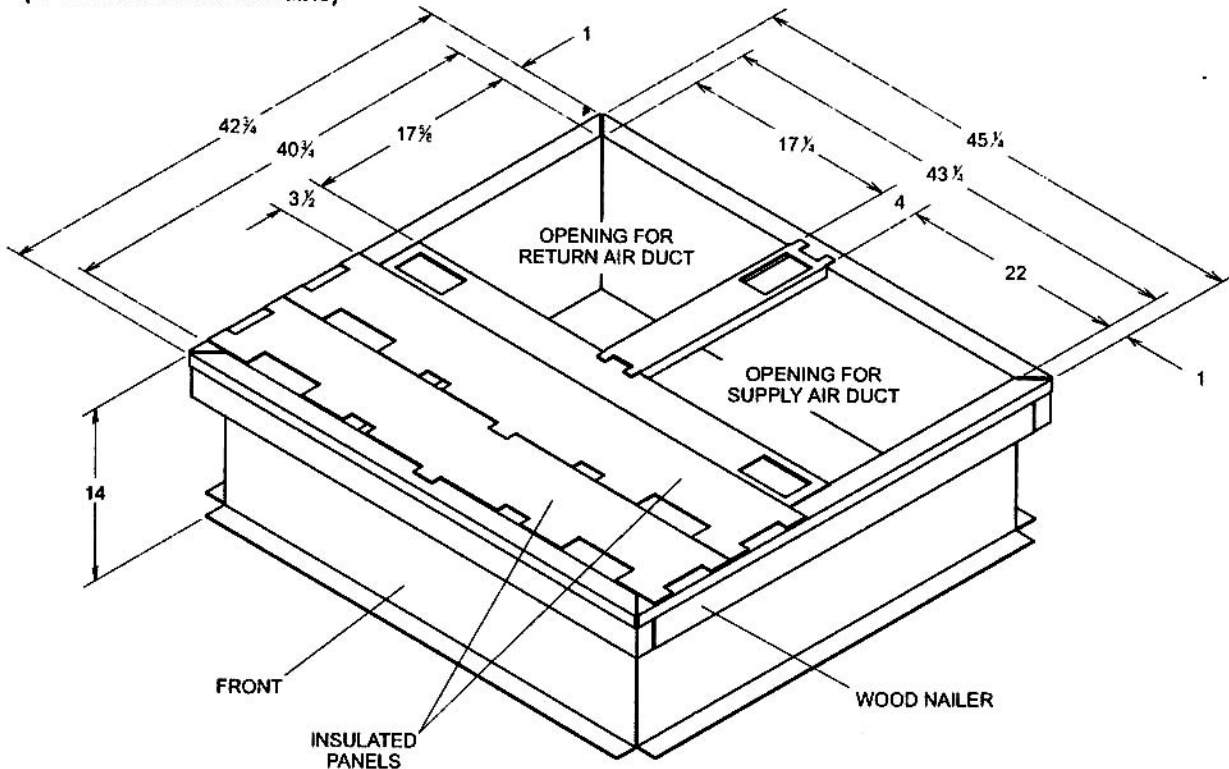

FIGURE 6 - TYPICAL APPLICATIONS

(8" roof curb also available)



RECOMMENDED DUCT SIZE	
SUPPLY AIR DUCT	17 1/8" x 21 1/2"
RETURN AIR DUCT	17 1/8" x 16 3/4"

ROOF CURB APPLICATION

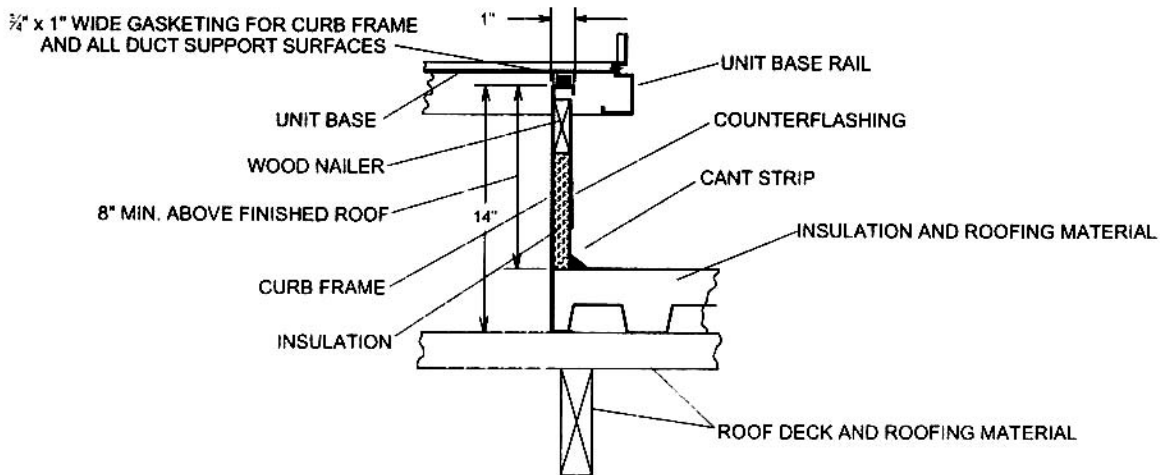

FIGURE 7 - ROOF CURB DIMENSIONS

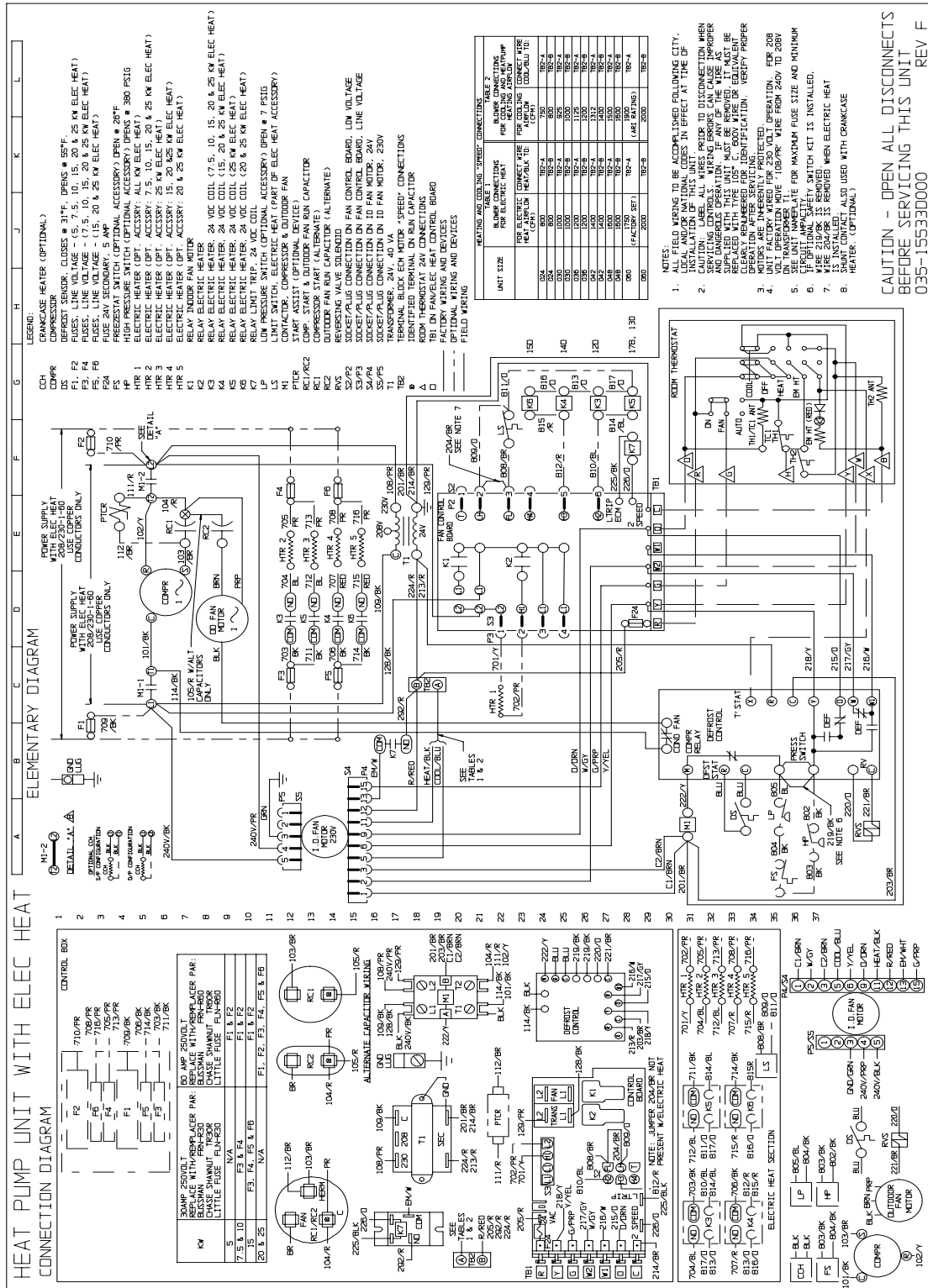

FIGURE 8 - TYPICAL WIRING DIAGRAM (208/230-1-60 POWER SUPPLY)

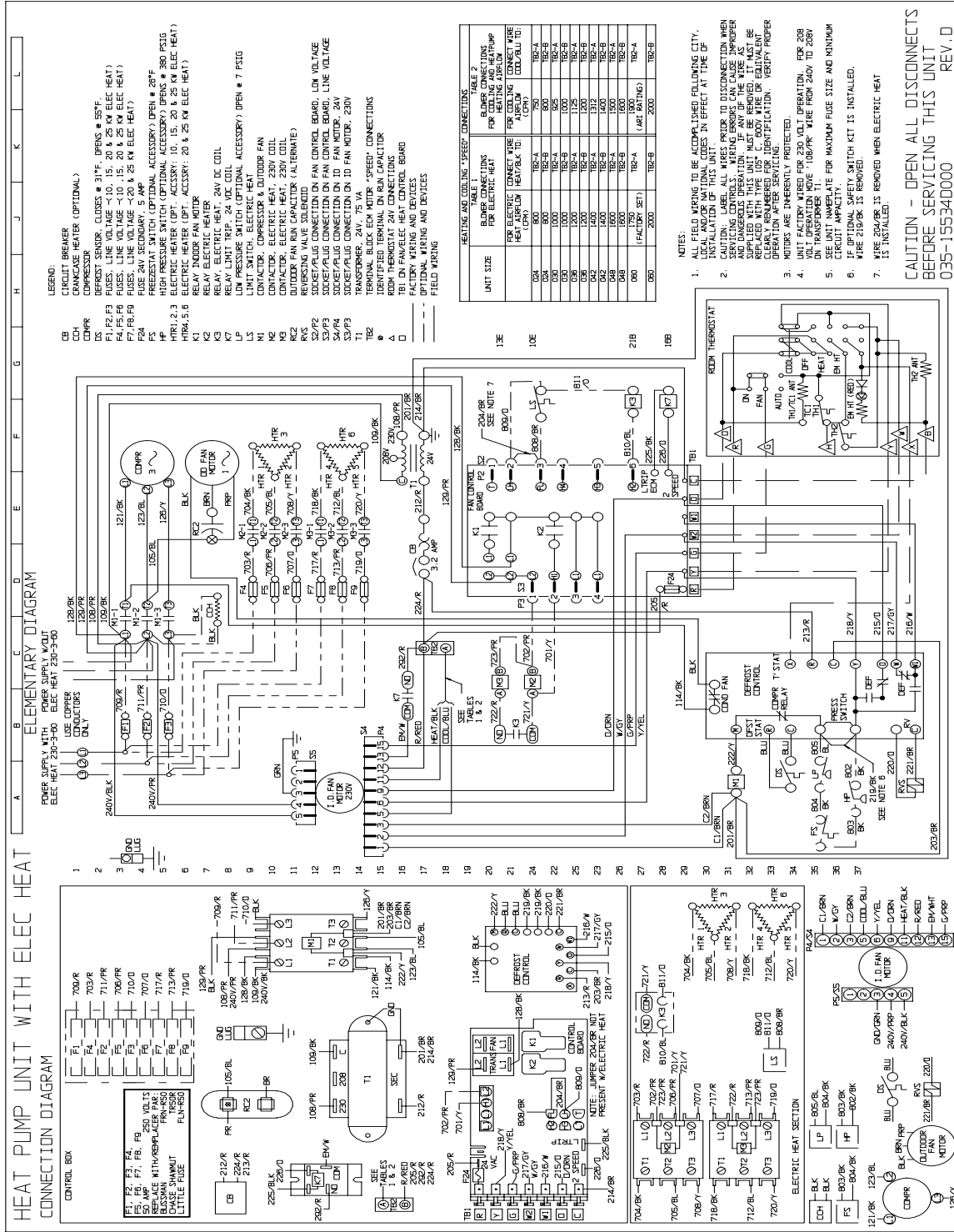

FIGURE 9 - TYPICAL WIRING DIAGRAM (230-3-60 POWER SUPPLY)

MECHANICAL SPECIFICATIONS

GENERAL DESCRIPTION

Units shall be factory-assembled, single packaged, Heat Pumps, designed for outdoor mounted installation. Units shall have minimum SEER ratings of 13.0. They shall have built in, equal size, field convertible duct connections for down discharge supply/return or horizontal discharge supply/return.

The units shall be factory wired, piped, charged with R-22 refrigerant and factory tested prior to shipment. All unit wiring shall be both numbered and color coded.

All units shall be manufactured in a facility certified to ISO 9001 standards, and the cooling performance shall be rated in accordance with DOE and ARI test procedures. Units shall be classified to UL 1995/CAN/CSA No. 236-M90 conditions.

UNIT CABINET

1. Unit cabinet shall be constructed of G90 galvanized steel, with exterior surfaces coated with a non-chalking, powered paint finish, certified at 1000 hours salt spray test per ASTM-B117 standards.
2. The unit top shall be a single piece "Water Shed" design, with drip edges and no-seam corners to provide optimum water integrity.
3. Unit shall have a rigidly mounted condenser coil guard to provide protection from objects and personnel after installation.
4. Indoor blower section shall be insulated with up to 3/4" thick, aluminum, foil faced insulation, fastened to prevent insulation from entering the air stream.
5. Cabinet panels shall be "large" size, easily removable for servicing and maintenance, with built-in lift handles.
6. Unit shall be built on a formed, "Super-Structure" design base pan, with embossments at critical points to add strength, rigidity and aid in minimizing sound.
7. Full perimeter base rails shall be provided to assure reliable transit of equipment, overhead rigging, fork truck access and proper sealing on roof curb applications. Base rails shall be removable, when required, to lower unit height.

8. Filters shall be furnished and be accessible through a removable access door, sealed air tight. (Single phase models - accessory kit available. Three phase models - standard from factory.)
9. Units vertical discharge and return duct configuration shall be designed to fit between standard 24" O.C. beams without modification to building structure, duct work and base unit.
10. Condensate pan shall be internally sloped and conform to ASHRAE 62-89 self-draining standards, with 3/4" NPTI copper, ridged mount connection.

INDOOR (SUPPLY) FAN ASSEMBLY

1. Fan shall be direct drive, constant CFM, ECM design. Job site selected (BHP) brake horse power shall not exceed the motors nameplate horse power rating.
2. Fan wheel shall be double-inlet type with forward-curved blades, dynamically balanced to operate smoothly throughout the entire range of operation. Airflow design shall be constant air volume.
3. Bearings shall be sealed and permanently lubricated for longer life and no maintenance.
4. Fan assembly shall be "Slip Track" (slide-out) design for easy removal and cleaning.

OUTDOOR FAN ASSEMBLY

1. The outdoor fan shall be of the direct-driven propeller type, discharge air vertically, have aluminum blades riveted to corrosion resistant steel spider bracket and shall be statically balanced for smooth operation.
2. The outdoor fan motor shall be totally enclosed with permanently lubricated bearings and internally protected against overload conditions.

REFRIGERANT COMPONENTS

1. Compressors:
 - A. Shall be fully hermetic type, direct drive, internally protected with internal high-pressure relief and over temperature protection. The hermetic motor shall be suction gas cooled and have a voltage range of + or - 10% of the unit nameplate voltage.

- B. Shall have internal isolation and sound muffling to minimize vibration and noise, and be externally isolated on a dedicated, independent mounting.
2. Coils:
 - A. Evaporator and condenser coils shall have aluminum plate fins mechanically bonded to seamless internally-enhanced copper tubes with all joints brazed.
 - B. Evaporator and Condenser coils shall be of the direct expansion, draw-thru design.
 3. Refrigerant Circuit and Refrigerant Safety Components shall include:
 - A. Independent thermal expansion devices (TXV).
 - B. Solid-core filter dryer to eliminate any foreign matter.
 - C. Accessible service gage connections on both suction and discharge lines to charge, evacuate, and measure refrigerant pressure during any necessary servicing or troubleshooting, without losing charge and without disrupting condenser or evaporator air flow.
 - D. The refrigeration system shall provide at least 10° F of liquid sub-cooling at design conditions.
 - E. Unit shall have a suction line accumulator and automatic reversing valve.
 4. Unit Controls:
 - A. Unit shall contain a large, low voltage Terminal Board for easy connection of field low voltage wiring.
 - B. Controls shall be mounted in a large control box with tilt-out, hinged access door, allowing easy access for trouble shooting and maintenance without affecting the normal system operation pressures.
 - C. Unit shall contain a reliable demand defrost control to provide defrost. The defrost control shall also have an "X" terminal to provide a 24 volt signal for

room thermostat "LED" indication of unit lockout. Plus a built in 5 minute anti-short cycle protection.

- D. Unit shall have large, easily removable panels, covering electrical controls and compressor, allowing easy access for any maintenance or servicing.

ELECTRIC HEATING SECTION

1. An electric heating section, with nickel chromium elements, shall be provided in a range of 5 thru 25 KW.
2. The heating section shall have an automatic reset primary limit control to prevent the heating element system from operating at an excessive temperature.
3. The heating section assembly shall slide out of the unit for easy maintenance and service.
4. Units with electric heating sections shall be wired for a single point power supply, with branch circuit fusing (where required).

UNIT OPERATING CHARACTERISTICS

1. Unit shall be capable of starting and running at 125° F outdoor temperature, exceeding maximum load criteria of ARI Standard 210/240.
2. The compressor, with standard controls, shall be capable of operation down to 45° F outdoor temperature.

ELECTRICAL REQUIREMENTS

All unit power wiring shall enter unit cabinet at a single factory provided location and be capable of side or bottom entry. This will minimize roof penetrations and avoid unit field modifications. Separate side and bottom openings shall be provided for the control wiring.



ISO 9001
Certified Quality
Management System

Subject to change without notice. Printed in U.S.A.
Copyright © by Unitary Products Group 2005. All rights reserved.

036-21528-005-A-0905
Supersedes: 036-21528-004-A-0505

**Unitary
Products
Group**

**5005
York
Drive**

**Norman
OK
73069**