



Heating and Air Conditioning

TECHNICAL GUIDE

SINGLE PACKAGE HEAT PUMP UNITS

BQ 036, 048 & 060

3, 4 & 5 NOMINAL TONS

10.0 SEER

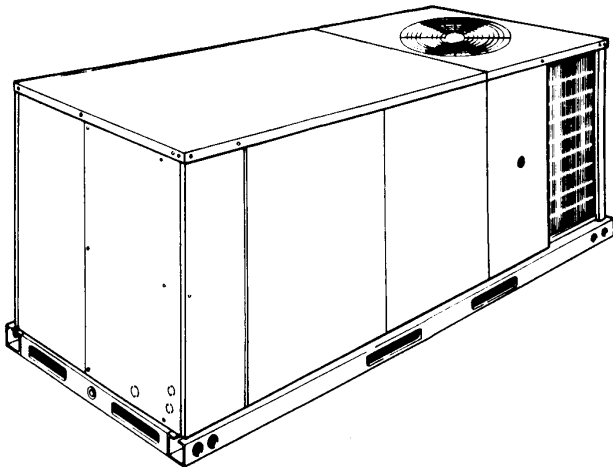

DESCRIPTION

YORK Sunline 2000™ heat pumps are convertible single package units with a common cabinet and a common roof curb for the 3, 4 and 5 ton sizes. The units were designed for light commercial and commercial applications. They can easily be installed on a roof curb, slab, roof jack or frame.

All units include:

- Powder Paint finish that meets ASTM-B-117 750 hour salt spray standards
- Permanently lubricated motors
- Bottom or side air discharge configuration capability (field convertible)
- Manufactured under the quality standards of ISO9001
- Simplicity™ Control Board
- Copper tube/aluminum fin coils
- Easy access to all components
- Rigging holes in base rails for lifting
- Fork lift slots on three sides
- Single point power connection
- Complete factory package - tested, charged and wired
- CSA agency listing on all units

WARRANTY

- Factory Limited Parts Warranty
- One-year parts warranty
- A Five-year parts warranty on the compressor and electric heat elements.



TABLE OF CONTENTS

DESCRIPTION	1	9 SUPPLY AIR BLOWER PERFORMANCE (5 TON BELT DRIVE) - SIDE DUCT APPLICATION.	22
PRODUCT NOMENCLATURE	3	10 SUPPLY AIR BLOWER PERFORMANCE (3 - 5 TON DIRECT DRIVE) - SIDE DUCT APPLICATION.	23
FEATURES	11	11 BELT DRIVE BLOWER MOTOR AND DRIVE DATA.	23
FACTORY-INSTALLED OPTIONS	12	12 STATIC RESISTANCES.	24
FIELD-INSTALLED ACCESSORIES	13	13 ELECTRIC HEATER CFM LIMITATIONS.	24
GUIDE SPECIFICATIONS	40	14 ELECTRICAL DATA - BQ036 & 048 DIRECT DRIVE WITHOUT POWR'D CONVENIENCE OUTLET	25

LIST OF FIGURES

<u>Fig. #</u>		<u>Pg. #</u>
1	UNIT CUTAWAY.....	12
2	TYPICAL FIELD POWER & CONTROL WIRING.....	34
3	UNIT DIMENSIONS (3 - 5 TON HEAT PUMP) FRONT VIEW	35
4	UNIT WITH ECONOMIZER RAINHOOD	35
5	UNIT WITH FIXED OUTDOOR AIR/MOTORIZED DAMPER RAINHOOD.....	36
6	UNIT DIMENSIONS (REAR VIEW).....	36
7	DISCONNECT/BLOWER ACCESS LOCATION	37
8	TYPICAL APPLICATIONS	38
9	FOUR AND SIX POINT LOADING	39
10	ROOF CURB DIMENSIONS.....	40

LIST OF TABLES

<u>Tbl. #</u>		<u>Pg. #</u>
1	SOUND POWER RATING	15
2	CAPACITY RATINGS.....	15
3	BQ036 COOLING CAPACITIES (3 TON)	16
4	BQ048 COOLING CAPACITIES (4 TON)	17
5	BQ060 COOLING CAPACITIES (5 TON)	18
6	BQ HEATING CAPACITIES	19
7	SUPPLY AIR BLOWER PERFORMANCE (3 TON BELT DRIVE) - SIDE DUCT APPLICATION.	20
8	SUPPLY AIR BLOWER PERFORMANCE (4 TON BELT DRIVE) - SIDE DUCT APPLICATION.	21
9	SUPPLY AIR BLOWER PERFORMANCE (5 TON BELT DRIVE) - SIDE DUCT APPLICATION.	22
10	SUPPLY AIR BLOWER PERFORMANCE (3 - 5 TON DIRECT DRIVE) - SIDE DUCT APPLICATION.	23
11	BELT DRIVE BLOWER MOTOR AND DRIVE DATA.	23
12	STATIC RESISTANCES.	24
13	ELECTRIC HEATER CFM LIMITATIONS.	24
14	ELECTRICAL DATA - BQ036 & 048 DIRECT DRIVE WITHOUT POWR'D CONVENIENCE OUTLET	25
15	ELECTRICAL DATA - BQ060 DIRECT DRIVE WITHOUT POWR'D CONVENIENCE OUTLET	26
16	ELECTRICAL DATA - BQ036 & 048 BELT DRIVE WITHOUT POWR'D CONVENIENCE OUTLET	27
17	ELECTRICAL DATA - BQ060 BELT DRIVE WITHOUT POWR'D CONVENIENCE OUTLET	28
18	ELECTRICAL DATA - BQ036 & 048 DIRECT DRIVE WITH POWR'D CONVENIENCE OUTLET	29
19	ELECTRICAL DATA - BQ060 DIRECT DRIVE WITH POWR'D CONVENIENCE OUTLET.	30
20	ELECTRICAL DATA - BQ036 & 048 BELT DRIVE WITH POWR'D CONVENIENCE OUTLET	31
21	ELECTRICAL DATA - BQ060 BELT DRIVE WITH POWR'D CONVENIENCE OUTLET	32
22	PHYSICAL DATA	33
23	ELECTRIC HEAT CORRECTION FACTORS	33
24	VOLTAGE LIMITATIONS	33
25	UTILITIES ENTRY	37
26	MINIMUM CLEARANCES.....	37
27	BQ 4 POINT LOADS WEIGHT DISTRIBUTION	39
28	BQ 6 POINT LOADS WEIGHT DISTRIBUTION	39
29	CENTER OF GRAVITY.....	39
30	OPERATING WEIGHTS (LBS.)	39

PRODUCT NOMENCLATURE

3-5 Ton Sunline Model Number Nomenclature

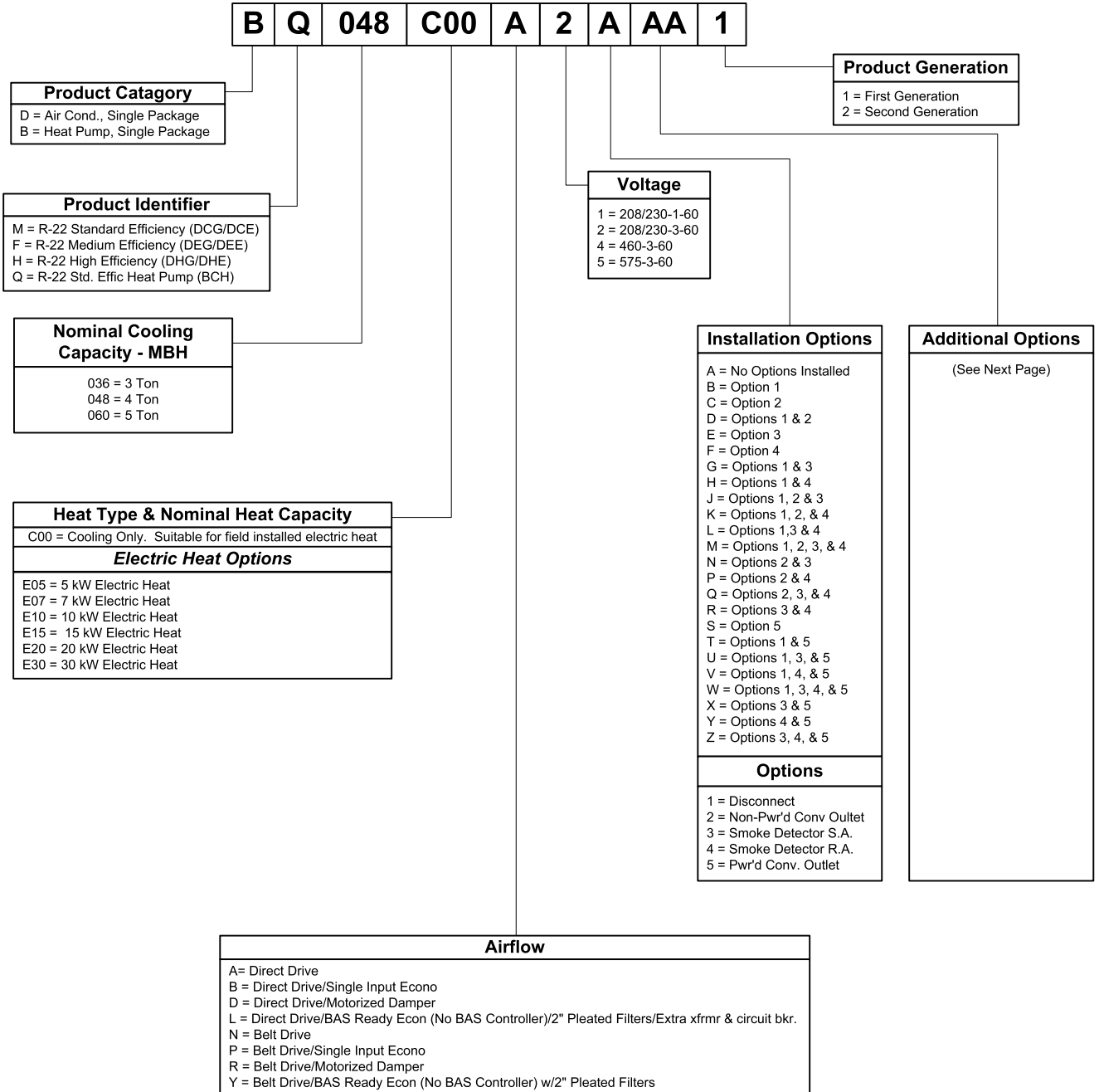

PRODUCT NOMENCLATURE - Continued

3-6T Sunline Model Number Nomenclature

Standard Cabinet	
AA	None
AB	Phase Monitor
AC	Coil Guard
AD	Dirty Filter Switch
AE	Phase Monitor & Coil Guard
AF	Phase Monitor & Dirty Filter Switch
AG	Coil Guard & Dirty Filter Switch
AH	Phase Monitor, Coil Guard, & Dirty Filter Switch
AJ	SS Drain Pan
AK	SS Drain Pan & Phase Monitor
AL	SS Drain Pan & Coil Guard
AM	SS Drain Pan & Dirty Filter Switch
AN	SS Drain Pan, Phase Monitor, Coil Guard & Dirty Filter Switch
AS	Bottom Drain Connection
CA	CPC Controller with Dirty Filter Switch & Air Proving Switch
CB	CPC Controller, DFS, APS & Phase Monitor
CC	CPC Controller, DFS, APS & Coil Guard
CD	CPC Controller, DFS, APS, Phase Monitor, & Coil Guard
CE	CPC Controller, DFS, APS & Technicoat Cond. Coil
CF	CPC Controller, DFS, APS, Technicoat Cond. Coil, & Phase Monitor
CG	CPC Controller, DFS, APS, Technicoat Cond. Coil, & Coil Guard
CH	CPC Controller, DFS, APS, Technicoat Cond. Coil, Phase Monitor, & Coil Guard
CJ	CPC Controller, DFS, APS & Technicoat Evap. Coil
CK	CPC Controller, DFS, APS, Technicoat Evap. Coil, & Phase Monitor
CL	CPC Controller, DFS, APS, Technicoat Evap. Coil, & Coil Guard
CM	CPC Controller, DFS, APS, Technicoat Evap. Coil, Phase Monitor, & Coil Guard
CN	CPC Controller, DFS, APS & Technicoat Evap. & Cond Coils
CP	CPC Controller, DFS, APS, Technicoat Evap. & Cond Coils, & Phase Monitor
CQ	CPC Controller, DFS, APS, Technicoat Evap. & Cond Coils, & Coil Guard
CR	CPC Controller, DFS, APS, Technicoat Evap. & Cond Coils, Phase Monitor, & Coil Guard
CS	CPC Controller, DFS, APS, SS Drain Pan
CT	CPC Controller, DFS, APS, SS Drain Pan, Phase Monitor, & Coil Guard
CU	CPC Controller, DFS, APS, SS Drain Pan, & Technicoat Cond Coils
CV	CPC Controller, DFS, APS, SS Drain Pan, & Technicoat Evap Coil
CW	CPC Controller, DFS, APS, SS Drain Pan, & Technicoat Evap and Cond Coils
CX	CPC Controller, DFS, APS, SS Drain Pan, Phase Monitor, Coil Guard, & Technicoat Evap and Cond Coils
JA	Johnson UNT Controller with Dirty Filter Switch & Air Proving Switch
JB	Johnson UNT Controller, DFS, APS & Phase Monitor
JC	Johnson UNT Controller, DFS, APS & Coil Guard
JD	Johnson UNT Controller, DFS, APS, Phase Monitor, & Coil Guard
JE	Johnson UNT Controller, DFS, APS & Technicoat Cond. Coil
JF	Johnson UNT Controller, DFS, APS, Technicoat Cond. Coil, & Phase Monitor
JG	Johnson UNT Controller, DFS, APS, Technicoat Cond. Coil, & Coil Guard
JH	Johnson UNT Controller, DFS, APS, Technicoat Cond. Coil, Phase Monitor, & Coil Guard
JJ	Johnson UNT Controller, DFS, APS & Technicoat Evap. Coil
JK	Johnson UNT Controller, DFS, APS, Technicoat Evap. Coil, & Phase Monitor
JL	Johnson UNT Controller, DFS, APS, Technicoat Evap. Coil, & Coil Guard
JM	Johnson UNT Controller, DFS, APS, Technicoat Evap. Coil, Phase Monitor, & Coil Guard
JN	Johnson UNT Controller, DFS, APS & Technicoat Evap. & Cond Coils
JP	Johnson UNT Controller, DFS, APS, Technicoat Evap. & Cond Coils, & Phase Monitor
JQ	Johnson UNT Controller, DFS, APS, Technicoat Evap. & Cond Coils, & Coil Guard

Standard Cabinet	
JR	Johnson UNT Controller, DFS, APS, Technicoat Evap. & Cond Coils, Phase Monitor, & Coil Guard
JS	Johnson UNT Controller, DFS, APS, SS Drain Pan
JT	Johnson UNT Controller, DFS, APS, SS Drain Pan, Phase Monitor, & Coil Guard
JU	Johnson UNT Controller, DFS, APS, SS Drain Pan, & Technicoat Cond Coils
JV	Johnson UNT Controller, DFS, APS, SS Drain Pan, & Technicoat Evap Coil
JW	Johnson UNT Controller, DFS, APS, SS Drain Pan, & Technicoat Evap and Cond Coils
JX	Johnson UNT Controller, DFS, APS, SS Drain Pan, Phase Monitor, Coil Guard, & Technicoat Evap and Cond Coils
HA	Honeywell Excel 10 Controller with Dirty Filter Switch & Air Proving Switch
HB	Honeywell Excel 10 Controller, DFS, APS & Phase Monitor
HC	Honeywell Excel 10 Controller, DFS, APS & Coil Guard
HD	Honeywell Excel 10 Controller, DFS, APS, Phase Monitor, & Coil Guard
HE	Honeywell Excel 10 Controller, DFS, APS & Technicoat Cond. Coil
HF	Honeywell Excel 10 Controller, DFS, APS, Technicoat Cond. Coil, & Phase Monitor
HG	Honeywell Excel 10 Controller, DFS, APS, Technicoat Cond. Coil, & Coil Guard
HH	Honeywell Excel 10 Controller, DFS, APS, Technicoat Cond. Coil, Phase Monitor, & Coil Guard
HJ	Honeywell Excel 10 Controller, DFS, APS & Technicoat Evap. Coil
HK	Honeywell Excel 10 Controller, DFS, APS, Technicoat Evap. Coil, & Phase Monitor
HL	Honeywell Excel 10 Controller, DFS, APS, Technicoat Evap. Coil, & Coil Guard
HM	Honeywell Excel 10 Controller, DFS, APS, Technicoat Evap. Coil, Phase Monitor, & Coil Guard
HN	Honeywell Excel 10 Controller, DFS, APS & Technicoat Evap. & Cond Coils
HP	Honeywell Excel 10 Controller, DFS, APS, Technicoat Evap. & Cond Coils, & Phase Monitor
HQ	Honeywell Excel 10 Controller, DFS, APS, Technicoat Evap. & Cond Coils, & Coil Guard
HR	Honeywell Excel 10 Controller, DFS, APS, Technicoat Evap. & Cond Coils, Phase Monitor, & Coil Guard
HS	Honeywell Excel 10 Controller, DFS, APS, SS Drain Pan
HT	Honeywell Excel 10 Controller, DFS, APS, SS Drain Pan, Phase Monitor, & Coil Guard
HU	Honeywell Excel 10 Controller, DFS, APS, SS Drain Pan, & Technicoat Cond Coils
HV	Honeywell Excel 10 Controller, DFS, APS, SS Drain Pan, & Technicoat Evap Coil
HW	Honeywell Excel 10 Controller, DFS, APS, SS Drain Pan, & Technicoat Evap and Cond Coils
HX	Honeywell Excel 10 Controller, DFS, APS, SS Drain Pan, Phase Monitor, Coil Guard, & Technicoat Evap and Cond Coils
NA	Novar ETC-3 Controller with Dirty Filter Switch & Air Proving Switch
NB	Novar ETC-3 Controller, DFS, APS & Phase Monitor
NC	Novar ETC-3 Controller, DFS, APS & Coil Guard
ND	Novar ETC-3 Controller, DFS, APS, Phase Monitor, & Coil Guard
NE	Novar ETC-3 Controller, DFS, APS & Technicoat Cond. Coil
NF	Novar ETC-3 Controller, DFS, APS, Technicoat Cond. Coil, & Phase Monitor
NG	Novar ETC-3 Controller, DFS, APS, Technicoat Cond. Coil, & Coil Guard
NH	Novar ETC-3 Controller, DFS, APS, Technicoat Cond. Coil, Phase Monitor, & Coil Guard
NJ	Novar ETC-3 Controller, DFS, APS & Technicoat Evap. Coil
NK	Novar ETC-3 Controller, DFS, APS, Technicoat Evap. Coil, & Phase Monitor
NL	Novar ETC-3 Controller, DFS, APS, Technicoat Evap. Coil, & Coil Guard
NM	Novar ETC-3 Controller, DFS, APS, Technicoat Evap. Coil, Phase Monitor, & Coil Guard
NN	Novar ETC-3 Controller, DFS, APS & Technicoat Evap. & Cond Coils
NP	Novar ETC-3 Controller, DFS, APS, Technicoat Evap. & Cond Coils, & Phase Monitor
NQ	Novar ETC-3 Controller, DFS, APS, Technicoat Evap. & Cond Coils, & Coil Guard
NR	Novar ETC-3 Controller, DFS, APS, Technicoat Evap. & Cond Coils, Phase Monitor, & Coil Guard
NS	Novar ETC-3 Controller, DFS, APS, SS Drain Pan
NT	Novar ETC-3 Controller, DFS, APS, SS Drain Pan, Phase Monitor, & Coil Guard
NU	Novar ETC-3 Controller, DFS, APS, SS Drain Pan, & Technicoat Cond Coils
NV	Novar ETC-3 Controller, DFS, APS, SS Drain Pan, & Technicoat Evap Coil
NW	Novar ETC-3, DFS, APS, SS Drain Pan, & Technicoat Evap and Cond Coils
NX	Novar ETC-3 Controller, DFS, APS, SS Drain Pan, Phase Monitor, Coil Guard, & Technicoat Evap and Cond Coils
TA	Technicoat Condenser Coil
TB	Technicoat Condenser Coil & Phase Monitor
TC	Technicoat Condenser Coil & Coil Guard

Standard Cabinet	
TD	Technicoat Condenser Coil & Dirty Filter Switch
TE	Technicoat Condenser Coil, Phase Monitor, & Coil Guard
TF	Technicoat Condenser Coil, Phase Monitor, & Dirty Filter Switch
TG	Technicoat Condenser Coil, Coil Guard, & Dirty Filter Switch
TH	Technicoat Condenser Coil, Phase Monitor, Coil Guard, & Dirty Filter Switch
TJ	Technicoat Evaporator Coil
TK	Technicoat Evaporator Coil & Phase Monitor
TL	Technicoat Evaporator Coil & Coil Guard
TM	Technicoat Evaporator Coil & Dirty Filter Switch
TN	Technicoat Evaporator Coil, Phase Monitor, & Coil Guard
TP	Technicoat Evaporator Coil, Phase Monitor, & Dirty Filter Switch
TQ	Technicoat Evaporator Coil, Coil Guard, & Dirty Filter Switch
TR	Technicoat Evaporator Coil, Phase Monitor, Coil Guard, & Dirty Filter Switch
TS	Technicoat Evaporator & Condenser Coils
TT	Technicoat Evaporator & Condenser Coils & Phase Monitor
TU	Technicoat Evaporator & Condenser Coils & Coil Guard
TV	Technicoat Evaporator & Condenser Coils & Dirty Filter Switch
TW	Technicoat Evaporator & Condenser Coils, Phase Monitor, & Coil Guard
TX	Technicoat Evaporator & Condenser Coils, Phase Monitor, & Dirty Filter Switch
TY	Technicoat Evaporator & Condenser Coils, Coil Guard, & Dirty Filter Switch
TZ	Technicoat Evaporator & Condenser Coils, Phase Monitor, Coil Guard, & Dirty Filter Switch
T1	Technicoat Condenser & SS Drain Pan
T3	Technicoat Condenser Coil, SS Drain Pan, Phase Monitor, Coil Guard, & Dirty Filter Switch
T4	Technicoat Evaporator & SS Drain Pan
T6	Technicoat Evaporator Coil, SS Drain Pan, Phase Monitor, Coil Guard, & Dirty Filter Switch
T7	Technicoat Evaporator & Condenser Coils & SS Drain Pan
T9	Technicoat Evaporator & Condenser Coils, SS Drain Pan, Phase Monitor, Coil Guard, & Dirty Filter Switch
LA	Simplicity Intelli-Comfort Controller
LB	Simplicity Intelli-Comfort Controller, & Phase Monitor
LC	Simplicity Intelli-Comfort Controller, & Coil Guard
LD	Simplicity Intelli-Comfort Controller, Phase Monitor, & Coil Guard
LE	Simplicity Intelli-Comfort Controller, & Technicoat Cond. Coil
LF	Simplicity Intelli-Comfort Controller, Technicoat Cond. Coil, & Phase Monitor
LG	Simplicity Intelli-Comfort Controller, Technicoat Cond. Coil, & Coil Guard
LH	Simplicity Intelli-Comfort Controller, Technicoat Cond. Coil, Phase Monitor, & Coil Guard
LJ	Simplicity Intelli-Comfort Controller, & Technicoat Evap. Coil
LK	Simplicity Intelli-Comfort Controller, Technicoat Evap. Coil, & Phase Monitor
LL	Simplicity Intelli-Comfort Controller, Technicoat Evap. Coil, & Coil Guard
LM	Simplicity Intelli-Comfort Controller, Technicoat Evap. Coil, Phase Monitor, & Coil Guard
LN	Simplicity Intelli-Comfort Controller, & Technicoat Evap. & Cond Coils
LP	Simplicity Intelli-Comfort Controller, Technicoat Evap. & Cond Coils, & Phase Monitor
LQ	Simplicity Intelli-Comfort Controller, Technicoat Evap. & Cond Coils, & Coil Guard
LR	Simplicity Intelli-Comfort Controller, Technicoat Evap. & Cond Coils, Phase Monitor, & Coil Guard
LS	Simplicity Intelli-Comfort Controller, SS Drain Pan
LT	Simplicity Intelli-Comfort Controller, SS Drain Pan, Phase Monitor, & Coil Guard
LU	Simplicity Intelli-Comfort Controller, SS Drain Pan, & Technicoat Cond Coils
LV	Simplicity Intelli-Comfort Controller, SS Drain Pan, & Technicoat Evap Coil
LW	Simplicity Intelli-Comfort Controller, SS Drain Pan, & Technicoat Evap and Cond Coils
LX	Simplicity Intelli-Comfort Controller, SS Drain Pan, Phase Monitor, Coil Guard, & Technicoat Evap and Cond Coils
WA	Intelli-Comfort w/Mod Link Controller
WB	Intelli-Comfort w/Mod Link Controller, & Phase Monitor
WC	Intelli-Comfort w/Mod Link Controller, & Coil Guard
WD	Intelli-Comfort w/Mod Link Controller, Phase Monitor, & Coil Guard
WE	Intelli-Comfort w/Mod Link Controller, & Technicoat Cond. Coil

Standard Cabinet	
WF	Intelli-Comfort w/Mod Link Controller, Technicoat Cond. Coil, & Phase Monitor
WG	Intelli-Comfort w/Mod Link Controller, Technicoat Cond. Coil, & Coil Guard
WH	Intelli-Comfort w/Mod Link Controller, Technicoat Cond. Coil, Phase Monitor, & Coil Guard
WJ	Intelli-Comfort w/Mod Link Controller, & Technicoat Evap. Coil
WK	Intelli-Comfort w/Mod Link Controller, Technicoat Evap. Coil, & Phase Monitor
WL	Intelli-Comfort w/Mod Link Controller, Technicoat Evap. Coil, & Coil Guard
WM	Intelli-Comfort w/Mod Link Controller, Technicoat Evap. Coil, Phase Monitor, & Coil Guard
WN	Intelli-Comfort w/Mod Link Controller, & Technicoat Evap. & Cond Coils
WP	Intelli-Comfort w/Mod Link Controller, Technicoat Evap. & Cond Coils, & Phase Monitor
WQ	Intelli-Comfort w/Mod Link Controller, Technicoat Evap. & Cond Coils, & Coil Guard
WR	Intelli-Comfort w/Mod Link Controller, Technicoat Evap. & Cond Coils, Phase Monitor, & Coil Guard
WS	Intelli-Comfort w/Mod Link Controller, SS Drain Pan
WT	Intelli-Comfort w/Mod Link Controller, SS Drain Pan, Phase Monitor, & Coil Guard
WU	Intelli-Comfort w/Mod Link Controller, SS Drain Pan, & Technicoat Cond Coils
WV	Intelli-Comfort w/Mod Link Controller, SS Drain Pan, & Technicoat Evap Coil
WW	Intelli-Comfort w/Mod Link Controller, SS Drain Pan, & Technicoat Evap and Cond Coils
WX	Intelli-Comfort w/Mod Link Controller, SS Drain Pan, Phase Monitor, Coil Guard, & Technicoat Evap and Cond Coils

Hinged Filter Door & Toolless Access Cabinet	
BA	Hinged Filter Door & Toolless Access Panels
BB	Phase Monitor, Hinged Filter Door & Toolless Access Panels
BC	Coil Guard, Hinged Filter Door & Toolless Access Panels
BD	Dirty Filter Switch, Hinged Filter Door & Toolless Access Panels
BE	Phase Monitor & Coil Guard, Hinged Filter Door & Toolless Access Panels
BF	Phase Monitor & Dirty Filter Switch, Hinged Filter Door & Toolless Access Panels
BG	Coil Guard & Dirty Filter Switch, Hinged Filter Door & Toolless Access Panels
BH	Phase Monitor, Coil Guard, & Dirty Filter Switch, Hinged Filter Door & Toolless Access Panels
BJ	SS Drain Pan & Hinged Filter Door & Toolless Access Panels
BK	SS Drain Pan & Phase Monitor, Hinged Filter Door & Toolless Access Panels
BL	SS Drain Pan & Coil Guard, Hinged Filter Door & Toolless Access Panels
BM	SS Drain Pan & Dirty Filter Switch, Hinged Filter Door & Toolless Access Panels
BN	SS Drain Pan & Phase Monitor & Coil Guard, Dirty Filter Switch, Hinged Filter Door & Toolless Access Panels
BS	Bottom Drain Connection, Hinged Filter Door & Toolless Access Panels
DA	CPC Controller with Dirty Filter Switch & Air Proving Switch, Hinged Filter Door & Toolless Access Panels
DB	CPC Controller, DFS, APS & Phase Monitor, Hinged Filter Door & Toolless Access Panels
DC	CPC Controller, DFS, APS & Coil Guard, Hinged Filter Door & Toolless Access Panels
DD	CPC Controller, DFS, APS, Phase Monitor, & Coil Guard, Hinged Filter Door & Toolless Access Panels
DE	CPC Controller, DFS, APS & Technicoat Cond. Coil, Hinged Filter Door & Toolless Access Panels
DF	CPC Controller, DFS, APS, Technicoat Cond. Coil, & Phase Monitor, Hinged Filter Door & Toolless Access Panels
DG	CPC Controller, DFS, APS, Technicoat Cond. Coil, & Coil Guard, Hinged Filter Door & Toolless Access Panels
DH	CPC Controller, DFS, APS, Technicoat Cond. Coil, Phase Monitor, & Coil Guard, Hinged Filter Door & Toolless Access Panels
DJ	CPC Controller, DFS, APS & Technicoat Evap. Coil, Hinged Filter Door & Toolless Access Panels
DK	CPC Controller, DFS, APS, Technicoat Evap. Coil, & Phase Monitor, Hinged Filter Door & Toolless Access Panels
DL	CPC Controller, DFS, APS, Technicoat Evap. Coil, & Coil Guard, Hinged Filter Door & Toolless Access Panels
DM	CPC Controller, DFS, APS, Technicoat Evap. Coil, Phase Monitor, & Coil Guard, Hinged Filter Door & Toolless Access Panels
DN	CPC Controller, DFS, APS & Technicoat Evap. & Cond Coils, Hinged Filter Door & Toolless Access Panels
DP	CPC Controller, DFS, APS, Technicoat Evap. & Cond Coils, & Phase Monitor, Hinged Filter Door & Toolless Access Panels
DQ	CPC Controller, DFS, APS, Technicoat Evap. & Cond Coils, & Coil Guard, Hinged Filter Door & Toolless Access Panels
DR	CPC Controller, DFS, APS, Technicoat Evap. & Cond Coils, Phase Monitor, & Coil Guard, Hinged Filter Door & Toolless Access Panels
DS	CPC Controller, DFS, APS, SS Drain Pan Hinged Filter Door & Toolless Access Panels
DT	CPC Controller, DFS, APS, SS Drain Pan, Phase Monitor, & Coil Guard Hinged Filter Door & Toolless Access Panels
DU	CPC Controller, DFS, APS, SS Drain Pan, & Technicoat Cond Coils Hinged Filter Door & Toolless Access Panels
DV	CPC Controller, DFS, APS, SS Drain Pan, & Technicoat Evap Coil Hinged Filter Door & Toolless Access Panels
DW	CPC Controller, DFS, APS, SS Drain Pan, & Technicoat Evap and Cond Coils Hinged Filter Door & Toolless Access Panels

Hinged Filter Door & Toolless Access Cabinet	
DX	CPC Controller, DFS, APS, SS Drain Pan, Phase Monitor, Coil Guard, & Technicoat Evap and Cond Coils Hinged Filter Door & Toolless Access Panels
EA	Johnson UNT Controller with Dirty Filter Switch & Air Proving Switch, Hinged Filter Door & Toolless Access Panels
EB	Johnson UNT Controller, DFS, APS & Phase Monitor, Hinged Filter Door & Toolless Access Panels
EC	Johnson UNT Controller, DFS, APS & Coil Guard, Hinged Filter Door & Toolless Access Panels
ED	Johnson UNT Controller, DFS, APS, Phase Monitor, & Coil Guard, Hinged Filter Door & Toolless Access Panels
EE	Johnson UNT Controller, DFS, APS & Technicoat Cond. Coil, Hinged Filter Door & Toolless Access Panels
EF	Johnson UNT Controller, DFS, APS, Technicoat Cond. Coil, & Phase Monitor, Hinged Filter Door & Toolless Access Panels
EG	Johnson UNT Controller, DFS, APS, Technicoat Cond. Coil, & Coil Guard, Hinged Filter Door & Toolless Access Panels
EH	Johnson UNT Controller, DFS, APS, Technicoat Cond. Coil, Phase Monitor, & Coil Guard, Hinged Filter Door & Toolless Access Panels
EJ	Johnson UNT Controller, DFS, APS & Technicoat Evap. Coil, Hinged Filter Door & Toolless Access Panels
EK	Johnson UNT Controller, DFS, APS, Technicoat Evap. Coil, & Phase Monitor, Hinged Filter Door & Toolless Access Panels
EL	Johnson UNT Controller, DFS, APS, Technicoat Evap. Coil, & Coil Guard, Hinged Filter Door & Toolless Access Panels
EM	Johnson UNT Controller, DFS, APS, Technicoat Evap. Coil, Phase Monitor, & Coil Guard, Hinged Filter Door & Toolless Access Panels
EN	Johnson UNT Controller, DFS, APS & Technicoat Evap. & Cond Coils, Hinged Filter Door & Toolless Access Panels
EP	Johnson UNT Controller, DFS, APS, Technicoat Evap. & Cond Coils, & Phase Monitor, Hinged Filter Door & Toolless Access Panels
EQ	Johnson UNT Controller, DFS, APS, Technicoat Evap. & Cond Coils, & Coil Guard, Hinged Filter Door & Toolless Access Panels
ER	Johnson UNT Controller, DFS, APS, Technicoat Evap. & Cond Coils, Phase Monitor, & Coil Guard, Hinged Filter Door & Toolless Access Panels
ES	Johnson UNT Controller, DFS, APS, SS Drain Pan Hinged Filter Door & Toolless Access Panels
ET	Johnson UNT Controller, DFS, APS, SS Drain Pan, Phase Monitor, & Coil Guard Hinged Filter Door & Toolless Access Panels
EU	Johnson UNT Controller, DFS, APS, SS Drain Pan, & Technicoat Cond Coils Hinged Filter Door & Toolless Access Panels
EV	Johnson UNT Controller, DFS, APS, SS Drain Pan, & Technicoat Evap Coil Hinged Filter Door & Toolless Access Panels
EW	Johnson UNT Controller, DFS, APS, SS Drain Pan, & Technicoat Evap and Cond Coils Hinged Filter Door & Toolless Access Panels
EX	Johnson UNT Controller, DFS, APS, SS Drain Pan, Phase Monitor, Coil Guard, & Technicoat Evap and Cond Coils Hinged Filter Door & Toolless Access Panels
GA	Honeywell Excel 10 Controller with Dirty Filter Switch & Air Proving Switch, Hinged Filter Door & Toolless Access Panels
GB	Honeywell Excel 10 Controller, DFS, APS & Phase Monitor, Hinged Filter Door & Toolless Access Panels
GC	Honeywell Excel 10 Controller, DFS, APS & Coil Guard, Hinged Filter Door & Toolless Access Panels
GD	Honeywell Excel 10 Controller, DFS, APS, Phase Monitor, & Coil Guard, Hinged Filter Door & Toolless Access Panels
GE	Honeywell Excel 10 Controller, DFS, APS & Technicoat Cond. Coil, Hinged Filter Door & Toolless Access Panels
GF	Honeywell Excel 10 Controller, DFS, APS, Technicoat Cond. Coil, & Phase Monitor, Hinged Filter Door & Toolless Access Panels
GG	Honeywell Excel 10 Controller, DFS, APS, Technicoat Cond. Coil, & Coil Guard, Hinged Filter Door & Toolless Access Panels
GH	Honeywell Excel 10 Controller, DFS, APS, Technicoat Cond. Coil, Phase Monitor, & Coil Guard, Hinged Filter Door & Toolless Access Panels
GJ	Honeywell Excel 10 Controller, DFS, APS & Technicoat Evap. Coil, Hinged Filter Door & Toolless Access Panels
GK	Honeywell Excel 10 Controller, DFS, APS, Technicoat Evap. Coil, & Phase Monitor, Hinged Filter Door & Toolless Access Panels
GL	Honeywell Excel 10 Controller, DFS, APS, Technicoat Evap. Coil, & Coil Guard, Hinged Filter Door & Toolless Access Panels
GM	Honeywell Excel 10 Controller, DFS, APS, Technicoat Evap. Coil, Phase Monitor, & Coil Guard, Hinged Filter Door & Toolless Access Panels
GN	Honeywell Excel 10 Controller, DFS, APS & Technicoat Evap. & Cond Coils, Hinged Filter Door & Toolless Access Panels
GP	Honeywell Excel 10 Controller, DFS, APS, Technicoat Evap. & Cond Coils, & Phase Monitor, Hinged Filter Door & Toolless Access Panels
GQ	Honeywell Excel 10 Controller, DFS, APS, Technicoat Evap. & Cond Coils, & Coil Guard, Hinged Filter Door & Toolless Access Panels
GR	Honeywell Excel 10 Controller, DFS, APS, Technicoat Evap. & Cond Coils, Phase Monitor, & Coil Guard, Hinged Filter Door & Toolless Access Panels
GS	Honeywell Excel 10 Controller, DFS, APS, SS Drain Pan
GT	Honeywell Excel 10 Controller, DFS, APS, SS Drain Pan, Phase Monitor, & Coil Guard
GU	Honeywell Excel 10 Controller, DFS, APS, SS Drain Pan, & Technicoat Cond Coils
GV	Honeywell Excel 10 Controller, DFS, APS, SS Drain Pan, & Technicoat Evap Coil
GW	Honeywell Excel 10 Controller, DFS, APS, SS Drain Pan, & Technicoat Evap and Cond Coils
GX	Honeywell Excel 10 Controller, DFS, APS, SS Drain Pan, Phase Monitor, Coil Guard, & Technicoat Evap and Cond Coils
PA	Novar ETC-3 Controller with Dirty Filter Switch & Air Proving Switch, Hinged Filter Door & Toolless Access Panels
PB	Novar ETC-3 Controller, DFS, APS & Phase Monitor, Hinged Filter Door & Toolless Access Panels

Hinged Filter Door & Toolless Access Cabinet	
PC	Novar ETC-3 Controller, DFS, APS & Coil Guard, Hinged Filter Door & Toolless Access Panels
PD	Novar ETC-3 Controller, DFS, APS, Phase Monitor, & Coil Guard, Hinged Filter Door & Toolless Access Panels
PE	Novar ETC-3 Controller, DFS, APS & Technicoat Cond. Coil, Hinged Filter Door & Toolless Access Panels
PF	Novar ETC-3 Controller, DFS, APS, Technicoat Cond. Coil, & Phase Monitor, Hinged Filter Door & Toolless Access Panels
PG	Novar ETC-3 Controller, DFS, APS, Technicoat Cond. Coil, & Coil Guard, Hinged Filter Door & Toolless Access Panels
PH	Novar ETC-3 Controller, DFS, APS, Technicoat Cond. Coil, Phase Monitor, & Coil Guard, Hinged Filter Door & Toolless Access Panels
PJ	Novar ETC-3 Controller, DFS, APS & Technicoat Evap. Coil, Hinged Filter Door & Toolless Access Panels
PK	Novar ETC-3 Controller, DFS, APS, Technicoat Evap. Coil, & Phase Monitor, Hinged Filter Door & Toolless Access Panels
PL	Novar ETC-3 Controller, DFS, APS, Technicoat Evap. Coil, & Coil Guard, Hinged Filter Door & Toolless Access Panels
PM	Novar ETC-3 Controller, DFS, APS, Technicoat Evap. Coil, Phase Monitor, & Coil Guard, Hinged Filter Door & Toolless Access Panels
PN	Novar ETC-3 Controller, DFS, APS & Technicoat Evap. & Cond Coils, Hinged Filter Door & Toolless Access Panels
PP	Novar ETC-3 Controller, DFS, APS, Technicoat Evap. & Cond Coils, & Phase Monitor, Hinged Filter Door & Toolless Access Panels
PQ	Novar ETC-3 Controller, DFS, APS, Technicoat Evap. & Cond Coils, & Coil Guard, Hinged Filter Door & Toolless Access Panels
PR	Novar ETC-3 Controller, DFS, APS, Technicoat Evap. & Cond Coils, Phase Monitor, & Coil Guard, Hinged Filter Door & Toolless Access Panels
PS	Novar ETC-3 Controller, DFS, APS, SS Drain Pan
PT	Novar ETC-3 Controller, DFS, APS, SS Drain Pan, Phase Monitor, & Coil Guard
PV	Novar ETC-3 Controller, DFS, APS, SS Drain Pan, & Technicoat Cond Coils
PW	Novar ETC-3 Controller, DFS, APS, SS Drain Pan, & Technicoat Evap Coil
PX	Novar ETC-3 Controller, DFS, APS, SS Drain Pan, & Technicoat Evap and Cond Coils
UA	Technicoat Condenser Coil, Hinged Filter Door & Toolless Access Panels
UB	Technicoat Condenser Coil & Phase Monitor, Hinged Filter Door & Toolless Access Panels
UC	Technicoat Condenser Coil & Coil Guard, Hinged Filter Door & Toolless Access Panels
UD	Technicoat Condenser Coil & Dirty Filter Switch, Hinged Filter Door & Toolless Access Panels
UE	Technicoat Condenser Coil, Phase Monitor, & Coil Guard, Hinged Filter Door & Toolless Access Panels
UF	Technicoat Condenser Coil, Phase Monitor, & Dirty Filter Switch, Hinged Filter Door & Toolless Access Panels
UG	Technicoat Condenser Coil, Coil Guard, & Dirty Filter Switch, Hinged Filter Door & Toolless Access Panels
UH	Technicoat Condenser Coil, Phase Monitor, Coil Guard, & Dirty Filter Switch, Hinged Filter Door & Toolless Access Panels
UJ	Technicoat Evaporator Coil, Hinged Filter Door & Toolless Access Panels
UK	Technicoat Evaporator Coil & Phase Monitor, Hinged Filter Door & Toolless Access Panels
UL	Technicoat Evaporator Coil & Coil Guard, Hinged Filter Door & Toolless Access Panels
UM	Technicoat Evaporator Coil & Dirty Filter Switch, Hinged Filter Door & Toolless Access Panels
UN	Technicoat Evaporator Coil, Phase Monitor, & Coil Guard, Hinged Filter Door & Toolless Access Panels
UP	Technicoat Evaporator Coil, Phase Monitor, & Dirty Filter Switch, Hinged Filter Door & Toolless Access Panels
UQ	Technicoat Evaporator Coil, Coil Guard, & Dirty Filter Switch, Hinged Filter Door & Toolless Access Panels
UR	Technicoat Evaporator Coil, Phase Monitor, Coil Guard, & Dirty Filter Switch, Hinged Filter Door & Toolless Access Panels
US	Technicoat Evaporator & Condenser Coils, Hinged Filter Door & Toolless Access Panels
UT	Technicoat Evaporator & Condenser Coils & Phase Monitor, Hinged Filter Door & Toolless Access Panels
UU	Technicoat Evaporator & Condenser Coils & Coil Guard, Hinged Filter Door & Toolless Access Panels
UV	Technicoat Evaporator & Condenser Coils & Dirty Filter Switch, Hinged Filter Door & Toolless Access Panels
UW	Technicoat Evaporator & Condenser Coils, Phase Monitor, & Coil Guard, Hinged Filter Door & Toolless Access Panels
UX	Technicoat Evaporator & Condenser Coils, Phase Monitor, & Dirty Filter Switch, Hinged Filter Door & Toolless Access Panels
UY	Technicoat Evaporator & Condenser Coils, Coil Guard, & Dirty Filter Switch, Hinged Filter Door & Toolless Access Panels
UZ	Technicoat Evaporator & Condenser Coils, Phase Monitor, Coil Guard, & Dirty Filter Switch, Hinged Filter Door & Toolless Access Panels
U1	Technicoat Condenser & SS Drain Pan, Hinged Filter Door & Toolless Access Panels
U3	Technicoat Condenser Coil, SS Drain Pan, Phase Monitor, Coil Guard, & Dirty Filter Switch, Hinged Filter Door & Toolless Access Panels
U4	Technicoat Evaporator & SS Drain Pan, Hinged Filter Door & Toolless Access Panels
U6	Technicoat Evaporator Coil, SS Drain Pan, Phase Monitor, Coil Guard, & Dirty Filter Switch, Hinged Filter Door & Toolless Access Panels
U7	Technicoat Evaporator & Condenser Coils & SS Drain Pan, Hinged Filter Door & Toolless Access Panels
U9	Technicoat Evaporator & Condenser Coils, SS Drain Pan, Phase Monitor, Coil Guard, & Dirty Filter Switch, Hinged Filter Door & Toolless Access Panels
QA	Simplicity Intelli-Comfort Controller with Hinged Filter Door & Toolless Access Panels
QB	Simplicity Intelli-Comfort Controller, & Phase Monitor, Hinged Filter Door & Toolless Access Panels
QC	Simplicity Intelli-Comfort Controller, & Coil Guard, Hinged Filter Door & Toolless Access Panels

FEATURES

All models are available with a wide variety of factory-mounted options such as electric heaters, phase monitor, convenience outlet, dirty filter switch, disconnect switch, smoke detectors, and coil guards to make them suitable for almost every application.

All units are self-contained and assembled on full perimeter base rails with forklift holes on three sides and holes for overhead rigging. Every unit is completely piped, wired, charged and tested at the factory to simplify the field installation and to provide years of dependable operation.

All models (including those with an economizer) are suitable for either bottom or horizontal duct connections. For bottom duct, remove the sheet metal panels from the supply and return air openings through the base of the unit. For horizontal duct, remove the supply and return air panels on the rear of the unit.

All models are available with these “factory mounted” outdoor air damper options:

- Single enthalpy economizer
- Motorized outdoor air damper

Supply air blowers are equipped with either a direct drive or a belt drive that can be adjusted to meet the exact requirements of the job.

All compressors are equipped with internal pressure relief. Every refrigerant circuit includes a liquid line filter-drier, a high pressure switch and a suction line with a freeze-stat and low pressure/loss of charge switch to protect all system components.

- **Simplicity™ Controls** - Simplicity™ control boards have standardized a number of features previously available only as options or by utilizing additional controls.
 - **Low Ambient** - An integrated low-ambient control allows all units to operate in the cooling mode down to 0°F outdoor ambient without additional assistance. Optionally, the control board can be programmed to lockout the compressors when the outdoor air temperature is low or when free cooling is available.
 - **Anti-Short Cycle Protection** - To aid compressor life, an anti-short cycle delay is incorporated into the standard controls. Compressor reliability is further ensured by programmable minimum run times. For testing, the anti short cycle delay can be temporarily overridden with the push of a button.

- **Fan Delays** - Fan on and fan off delays are fully programmable and are independent of one another. All units are programmed with default values based upon their configuration of cooling and heat.
- **Safety Monitoring** - The control board monitors the high and low-pressure switches, the freeze-stats, the gas valve, if applicable, and the temperature limit switch on gas heat units. The unit control board will alarm on ignition failures, compressor lockouts and repeated limit switch trips.
- **Nuisance Trip Protection** - To prevent nuisance trouble calls, the control board uses a “three strikes, you’re out” philosophy. The high and low-pressure switches and the freeze-stats must trip three times within two hours before the unit control board will lock out the compressor.
- **On Board Diagnostics** - Each alarm will energize a trouble light on the thermostat, if so equipped, and flash an alarm code on the control board LED. Each high and low-pressure switch alarm as well as each freeze-stat alarm has its own flash code. The control board saves the five most recent alarms in memory, and these alarms can be reviewed at any time. Alarms and programmed values are retained through the loss of power.

All units have long lasting powder paint cabinets with 750 hour salt spray test approval under ASTM-B117 procedures.

All models are CSA listed.

- **Warranty** - All models include a one-year limited parts warranty on the complete unit. Compressors and electric heater elements carry a five-year warranty
- **Electric Heat Operation** - All electric heat models are wired for a single power source and include a bank of nickel chromium elements mounted at the discharge of the supply air blower to provide a high velocity and uniform distribution of air across the heating elements. Every element is fully protected against excessive temperature by thermal limit switches.

The power supply wiring can be routed into the control box through a threaded pipe connection (field supplied) in the base pan of the unit or through a knockout in the wiring panel on the side of the unit.
- **BAS Controls** - York’s Sunline™ series units offer factory mounted BAS controls such as Simplicity™ INTELLI-Comfort™, Novar, Honeywell, Johnson, and CPC.

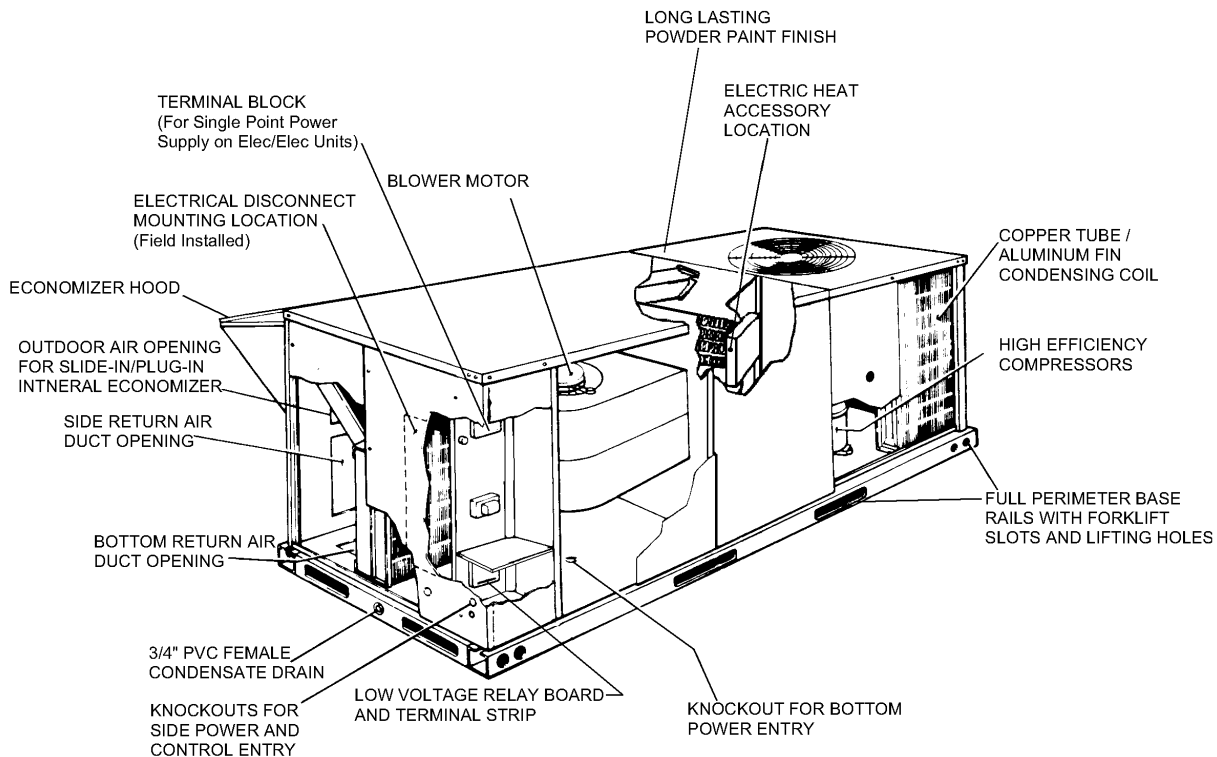

FIGURE 1 - UNIT CUTAWAY

FACTORY-INSTALLED OPTIONS

- **SINGLE INPUT ELECTRONIC ENTHALPY ECONOMIZERS** - Includes a slide-in / plug-in damper assembly with fully modulating spring-return motor actuator capable of introducing up to 100% outdoor air with nominal 1% leakage type dampers.

The enthalpy system contains one sensor that monitors the outdoor air and determines when the air is cool enough and dry enough to provide free cooling.

The rainhood is painted to match the basic unit and must be field-assembled before installing.

- **MOTORIZED OUTDOOR AIR INTAKE DAMPER** - Includes a slide-in / plug-in damper assembly with a 2-position, spring return motor actuator which opens to a pre-set position whenever the supply air blower is operating and will drive fully closed when the blower unit shuts down.

The rain hood is painted to match the basic unit and must be field assembled before installing.

- **PHENOLIC COATED EVAPORATOR AND CONDENSER COILS** - Special coating process that utilizes Technicoat 10-1™ processes. Coating is applied by total immersion of the complete coil for maximum protection.

- **ELECTRIC HEATERS** - Wired for single point power supply. These nickel chromium heater elements are provided with limit and automatic reset capability to prevent operation at excessive temperatures.
- **FILTER OPTIONS** - Standard units are shipped with 1" throw-away filters installed. 2" pleated filters are offered as a factory installed option.
- **CONVENIENCE OUTLET** - This 110 volt outlet can be "powered" by the unit with a stepdown transformer or the unit may be ordered with a "non-powered" convenience outlet that can be wired in the field.
- **DISCONNECT SWITCH** - For heat pump units with electric heat, an HACR breaker sized to the unit is provided. For heat pump units without electric heat, a switch sized to the largest electric heat available for the particular unit is provided. Factory-installed option only.
- **BAS - Building Automation System Controls**
Simplicity™ INTELLI-Comfort™ CONTROL - The York® Simplicity™ INTELLI-Comfort™ control is factory installed. It includes a supply air sensor, a return air sensor, and an outside air sensor. There are provisions for a field installed dirty filter indicator switch, an air-proving switch, an Outside Air Humidity sensor, a Return Air Humidity sensor, an Inside IAQ sensor, and an Outside

Air IAQ sensor. Construction mode operation, 365-day real time clock with 7 day programming plus holiday scheduling is built-in. Two different modes of demand ventilation are achieved through the INTELLI-Comfort™ using CO2 sensors. It uses an inside CO2 sensor to perform Demand Ventilation. It can also use an Outside CO2 sensor to perform Differential Demand Ventilation. It uses a Patented Comfort Ventilation algorithm to provide comfortable ventilation air temperature. The patented economizer-loading algorithm will protect the equipment when harsh operating conditions exist. Humidity in the occupied space or return duct can be monitored and controlled via humidity sensors and the on-board connection for hot gas re-heat system. It uses the INTELLI-Start™ algorithm to maximize energy savings by recovering the building from the Unoccupied Setpoints to the Occupied Setpoints just in time for the Occupied Time Period to begin. The Simplicity™ INTELLI-Comfort™ balances space temperature, ventilation air temperature, CO2 and humidity for ultimate comfort.

- **Simplicity™ INTELLI-Comfort™ with MOD LINK CONTROL** - The York® Simplicity™ INTELLI-Comfort™ with Mod Link control is factory installed. It includes all the features of the INTELLI-Comfort™ control with an additional control to translate communications from MOD-BUS to the BACnet MSTP protocol.
- **Novar® BAS CONTROL** - The Novar® ETC-3 building automation system controller is factory installed. Includes supply air sensor, return air sensor, dirty filter indicator switch, and air proving switch.
- **JOHNSON CONTROLS BAS CONTROL** - The Johnson Control YK-UNT-1126 building automation system controller is factory installed. Includes supply air sensor, return air sensor, dirty filter indicator switch, and air proving switch.
- **CPC BAS CONTROL** - The Computer Process Controls Model 810-3060 ARTC Advanced Rooftop building automation system controller is factory installed. Includes supply air sensor, return air sensor, dirty filter indicator switch and air proving switch.
- **HONEYWELL BAS CONTROL** - The Honeywell W7750C building automation system controller is factory installed. Includes air supply sensor, return air sensor, dirty filter indicator switch, and air proving switch.
- **SMOKE DETECTORS** - (supply air & return air) The smoke detectors stop operation of the unit by interrupting power to the control board if smoke is detected within the air compartment.
- **STAINLESS STEEL DRAIN PAN** - An optional rust-proof stainless steel drain pan is available to provide years of trouble-free operation in corrosive environments.
- **BOTTOM DRAIN CONNECTION** - An optional bottom drain connection is available for inside the curb connections for applications in cold environments to reduce freezing drain lines.
- **COIL GUARD** - Customers can purchase a coil guard kit to protect the condenser coil from damage. This is not a hail guard kit.
- **PHASE MONITORS** - Designed to prevent unit damage. The phase monitor will shut the unit down in an out-of-phase condition.
- **DIRTY FILTER SWITCH** - This kit includes a differential pressure switch that energizes the fault light on the unit thermostat, indicating that there is an abnormally high pressure drop across the filters. Factory installed option or field installed accessory.
- **HINGED FILTER DOOR/"TOOLLESS" BLOWER AND ACCESS PANELS** (not hinged) - This option allows for easy access and maintenance.

NOTE: Knobs are shipped inside the unit to prevent shipping damage. These must be field installed for tool-less operation.

FIELD-INSTALLED ACCESSORIES

- **SINGLE INPUT ELECTRONIC ENTHALPY ECONOMIZERS** - Includes a slide-in / plug-in damper assembly with fully modulating spring-return motor actuator capable of introducing up to 100% outdoor air with nominal 1% leakage type dampers.

The enthalpy system contains one sensor that monitors the outdoor air and determines when the air is cool enough and dry enough to provide free cooling.

The rainhood is painted to match the basic unit and must be field-assembled before installing.

- **MOTORIZED OUTDOOR AIR INTAKE DAMPER** - Includes a slide-in / plug-in damper assembly with a 2-position, spring return motor actuator which opens to some pre-set position whenever the supply air blower is operating and will drive fully closed when the blower unit shuts down.

The rain hood is painted to match the basic unit and must be field assembled before installing.

- **ELECTRIC HEATERS** wired for single point power supply. These nickel chromium heater elements are provided with limit and automatic reset capability to prevent operation at excessive temperatures.
- **ROOF CURBS** - Eight and fourteen-inch high roof curbs provide a water-tight seal between the unit and the finished roof. These full perimeter curbs meet the requirements of the National Roofing Contractors Association (NRCA) and are shipped knocked-down for field assembly.

Roof curbs are designed to fit inside the base rails of the unit and include both a wood nailing strip and duct hanger supports.

- **POWER EXHAUST** - Our single input economizer options are available with power exhaust. Whenever the outdoor air intake dampers are opened for free cooling, the exhaust fan will be energized to prevent the conditioned space from being over-pressurized during economizer operation.

The power exhaust option can only be used on bottom duct configurations.

- **BAROMETRIC RELIEF DAMPER** - This damper accessory can be used to relieve internal building air pressure on units with an economizer without power exhaust. This accessory includes a rain hood, a bird screen and a fully assembled damper. With bottom duct connections, the damper should be mounted over the opening in the

return air panel. With horizontal ductwork, the accessory should be mounted on the return air duct.

- **ENTHALPY ACCESSORY CONTROL KIT** - This kit contains the required components to convert a single enthalpy economizer to dual enthalpy.
- **BURGLAR BARS** - Mount in the supply and return openings to prevent entry into the duct work.
- **CO₂ SENSOR** - Senses CO₂ levels and automatically overrides the economizer when levels rise above the present limits.
- **COIL GUARD** - Customers can purchase a coil guard kit to protect the condenser coil from damage. This is not a hail guard kit.
- **HAIL GUARD** - Hail guard is available to protect the unit from hail damage. This is a sloped hood that fits above the coil.

TABLE 1: SOUND POWER RATING¹

UNIT SIZE	CFM	ESP	BLOWER		SOUND POWER (db 10 ⁻¹² Watts)									SWL dB(A)	dB(A) @ 10Ft. ²
					Octave Band Centerline Frequency (Hz)										
					IWG	SPEED	KW	63	125	250	500	1,000	2,000		
036	1,200	0.6	LOW	0.60	84	84	74	67	69	62	57	52	74	41	
048	1,600	0.55	HIGH	0.80	85	85	75	68	70	63	58	53	75	42	
060	2,000	0.45	HIGH	1.00	86	86	76	69	71	64	59	54	76	43	

1. These values have been accessed using a model of sound propagation from a point source into the hemispheric/free field. The dBA values provided are to be used for reference only. Calculation of dBA values cover matters of system design and the fan manufacture has no way of knowing the details of each system. This constitutes an expectation to any specification or guarantee requiring a dBA value or sound data in any other form than sound power level ratings.
2. At a distance of 10 feet from the blower.

TABLE 2: CAPACITY RATINGS

UNIT SIZE (MBH)	ARI RATINGS ¹								
	COOLING PERFORMANCE			SOUND RATING ² bels	HSPF	HEATING CAPACITY			
	MBH	SEER	EER			47°F		17°F	
				MBH	COP	MBH	COP		
036	39	10.00	9.20	8.6	7.3	39.0	3.0	23.0	2.1
048	48	10.20	9.25	8.6	6.7	48.0	3.0	26.4	2.0
060	59	10.00	9.20	8.4	7.0	59.0	3.0	36.0	2.1

NOTES:

1. Certified in accordance with the Unitary Small Equipment certification program, which is based on ARI Standard 210/240.
2. Rated in accordance with ARI Standard 270.

SEER = Seasonal Energy Efficiency Ratio - the total cooling output in BTU's during a normal annual usage period for cooling divided by the total electric power input in watt-hours during the same period.

EER = Energy Efficiency Ratio - the cooling capacity in BTU's per hour (BTUH) divided by the power input in watts at any given set of rating conditions, expressed in BTUH per watt (BTUH/watt).

COP = Coefficient of Performance - the total heating capacity provided by the refrigeration system, including circulating fan heat but excluding supplementary resistance (BTU's per hour) divided by the total electric input (watts) x 3.412.

HSPF = Heating Seasonal Performance Factor - the total heating output during a normal annual usage period for heating divided by the total electric power input during the same period. (Based on Region IV minimum design heating requirement).

TABLE 3: BQ036 COOLING CAPACITIES (3 TON)

AIR ON EVAPORATOR COIL		TEMPERATURE OF AIR ON CONDENSER COIL																	
		85°F								95°F									
		TOTAL CAP. ¹ MBH	POWER INPUT ² kW	SENSIBLE CAPACITY ¹						TOTAL CAP. ¹ MBH	POWER INPUT ² kW	SENSIBLE CAPACITY ¹							
				ENTERING DRY BULB, °F								ENTERING DRY BULB, °F							
CFM	WB °F	86	83	80	77	74	71	68	86	83	80	77	74	71	68				
1750	72	51	3.4	37	32	28	24	19	-	-	47	3.7	34	29	25	22	17	-	-
	67	46	3.4	40	40	36	31	26	21	16	44	3.7	38	38	34	29	24	20	15
	62	42	3.3	42	42	41	39	34	29	24	38	3.6	38	38	37	35	30	26	21
	57	42	3.3	42	42	42	40	35	30	25	37	3.6	37	37	37	35	30	26	22
1500	72	49	3.4	35	30	26	22	18	-	-	46	3.7	32	28	24	20	16	-	-
	67	45	3.4	39	37	33	29	24	20	15	42	3.7	36	34	30	27	22	18	14
	62	41	3.3	41	41	40	37	32	28	24	37	3.6	37	37	36	33	28	25	21
	57	41	3.3	41	41	41	38	34	29	25	36	3.6	36	36	36	33	29	25	21
1400	72	48	3.4	33	29	24	20	16	-	-	45	3.7	30	27	22	18	15	-	-
	67	44	3.3	39	36	32	28	23	20	15	41	3.7	36	33	29	26	21	18	13
	62	40	3.3	40	39	38	34	30	26	22	36	3.6	36	35	34	30	27	23	19
	57	40	3.3	40	40	39	35	31	27	23	36	3.5	36	36	35	31	27	24	20
1200	72	47	3.4	31	27	24	20	16	-	-	44	3.7	29	25	22	18	14	-	-
	67	41	3.3	36	32	29	25	22	18	14	39	3.6	34	30	27	23	20	17	13
	62	38	3.3	38	37	36	32	29	25	21	35	3.6	35	34	33	29	26	23	19
	57	37	3.3	37	37	36	33	30	26	22	35	3.5	35	35	34	31	28	24	20
1050	72	45	3.3	28	25	22	19	16	-	-	42	3.6	26	23	20	17	14	-	-
	67	41	3.3	34	30	27	24	20	17	14	38	3.6	31	27	25	22	18	15	12
	62	36	3.3	36	35	33	30	27	24	21	34	3.5	34	33	31	28	25	22	19
	57	36	3.3	36	36	34	31	28	25	22	33	3.5	33	33	31	28	25	22	20
900	72	45	3.3	26	24	20	17	15	-	-	40	3.6	23	21	17	15	13	-	-
	67	39	3.3	31	28	25	22	19	17	14	35	3.6	27	25	22	19	17	15	12
	62	35	3.2	35	34	32	29	25	23	20	32	3.5	32	30	28	25	22	20	17
	57	35	3.2	35	35	32	30	26	24	21	31	3.5	31	31	28	26	23	21	18

AIR ON EVAPORATOR COIL		TEMPERATURE OF AIR ON CONDENSER COIL																	
		105°F								115°F									
		TOTAL CAP. ¹ MBH	POWER INPUT ² kW	SENSIBLE CAPACITY ¹						TOTAL CAP. ¹ MBH	POWER INPUT ² kW	SENSIBLE CAPACITY ¹							
				ENTERING DRY BULB, °F								ENTERING DRY BULB, °F							
CFM	WB °F	86	83	80	77	74	71	68	86	83	80	77	74	71	68				
1750	72	44	4.0	31	27	24	20	16	-	-	42	4.2	30	26	23	19	15	-	-
	67	40	4.0	34	34	31	26	22	18	13	36	4.1	31	31	28	24	20	16	12
	62	35	3.9	35	35	34	32	28	24	20	34	4.1	34	34	33	31	27	23	19
	57	35	3.9	35	35	35	33	29	25	20	33	4.1	33	33	33	31	27	23	19
1500	72	43	4.0	30	26	22	19	15	-	-	41	4.2	29	25	21	18	15	-	-
	67	38	4.0	32	31	27	24	20	16	12	35	4.1	30	28	25	22	18	15	11
	62	34	3.9	34	34	33	30	26	23	19	33	4.1	33	33	32	29	25	22	19
	57	34	3.9	34	34	34	31	28	24	20	32	4.1	32	32	32	29	26	22	19
1400	72	42	4.0	28	25	21	17	14	-	-	39	4.2	26	23	19	16	13	-	-
	67	37	4.0	32	30	26	23	19	16	12	34	4.1	30	27	24	21	17	15	11
	62	33	3.9	33	32	31	28	24	21	18	32	4.1	32	31	30	27	24	20	17
	57	32	3.8	32	32	31	28	24	21	18	32	4.0	32	32	31	28	24	21	18
1200	72	41	4.0	27	23	20	17	13	-	-	37	4.2	24	21	18	15	12	-	-
	67	35	3.9	30	27	24	21	18	15	11	32	4.1	28	24	22	19	17	14	10
	62	32	3.9	32	31	30	26	24	21	17	30	4.1	30	29	28	25	22	19	16
	57	31	3.8	31	31	31	27	25	21	18	29	4.0	29	29	29	25	23	20	17
1050	72	40	3.9	24	22	19	16	14	-	-	35	4.1	21	19	17	14	12	-	-
	67	34	3.9	28	24	22	19	16	14	11	31	4.0	25	22	20	18	15	12	10
	62	30	3.8	30	29	27	25	22	20	17	29	4.0	29	28	26	24	21	19	16
	57	30	3.8	30	30	28	25	23	20	18	28	4.0	28	28	26	24	21	19	17
900	72	38	3.9	21	20	16	14	12	-	-	34	4.1	19	18	15	12	11	-	-
	67	32	3.9	25	22	20	18	15	13	11	29	4.0	23	20	18	16	14	12	10
	62	29	3.8	29	27	25	23	20	18	16	27	4.0	27	25	24	21	18	17	15
	57	29	3.8	29	29	26	24	21	19	17	26	4.0	26	26	23	22	19	17	15

1. These capacities are gross ratings. For net capacity, determine the kW of the supply air blower motor from the SUPPLY AIR BLOWER PERFORMANCE Table, multiply this value by 3.415 MBH/kW to determine the motor heat, and deduct this heat from the gross capacity of the unit.
 2. These ratings include the compressor and the condenser fan motors but not the supply air blower motor. The total condenser fan motor power input is 0.35kW. Refer to the SUPPLY AIR BLOWER PERFORMANCE Table for the kW of the supply air blower motor.

NOMINAL RATING

TABLE 4: BQ048 COOLING CAPACITIES (4 TON)

AIR ON EVAPORATOR COIL		TEMPERATURE OF AIR ON CONDENSER COIL																	
		85°F								95°F									
		TOTAL CAP. ¹ MBH	POWER INPUT ² kW	SENSIBLE CAPACITY ¹						TOTAL CAP. ¹ MBH	POWER INPUT ² kW	SENSIBLE CAPACITY ¹							
				ENTERING DRY BULB, °F								ENTERING DRY BULB, °F							
CFM	WB °F	86	83	80	77	74	71	68	86	83	80	77	74	71	68				
2000	72	56	4.1	42	36	31	26	-	-	-	53	4.5	40	35	29	24	-	-	-
	67	53	4.0	48	47	41	36	30	25	-	51	4.4	46	45	41	35	30	24	-
	62	49	4.0	49	49	48	44	38	33	28	46	4.3	46	46	45	41	35	30	24
	57	49	3.9	49	49	49	44	38	33	28	46	4.3	46	46	46	41	35	30	24
1800	72	55	4.0	40	35	30	25	-	-	-	53	4.4	38	33	28	23	-	-	-
	67	52	4.0	47	44	39	34	29	24	-	51	4.4	44	44	39	34	29	24	-
	62	48	3.9	48	48	47	43	38	33	28	47	4.3	47	47	45	40	36	31	26
	57	48	3.9	48	48	48	43	38	33	28	45	4.2	45	45	45	40	35	30	25
1600	72	53	4.0	37	33	28	24	-	-	-	52	4.4	36	32	27	23	-	-	-
	67	51	4.0	46	42	37	33	28	24	-	50	4.3	44	43	38	34	29	25	-
	62	47	3.9	47	47	46	41	37	32	28	45	4.2	45	45	44	40	36	31	27
	57	47	3.9	47	47	47	42	38	33	29	44	4.1	44	44	44	40	36	31	27
1400	72	52	4.0	34	30	26	22	-	-	-	49	4.3	33	29	25	21	-	-	-
	67	49	3.9	42	38	34	30	26	22	-	47	4.2	42	38	34	30	26	22	-
	62	46	3.8	46	45	42	38	34	30	26	43	4.1	43	42	40	36	32	28	24
	57	45	3.8	45	45	43	39	35	31	27	42	4.1	42	42	40	36	32	28	24
1200	72	50	3.9	31	27	24	20	-	-	-	47	4.2	29	25	22	18	-	-	-
	67	47	3.9	38	35	31	28	24	21	-	45	4.2	37	34	30	27	23	20	-
	62	44	3.8	44	42	39	35	32	28	25	40	4.1	40	39	36	32	29	25	22
	57	44	3.7	44	43	39	36	32	29	25	40	4.0	40	39	36	32	29	25	22

AIR ON EVAPORATOR COIL		TEMPERATURE OF AIR ON CONDENSER COIL																	
		105°F								115°F									
		TOTAL CAP. ¹ MBH	POWER INPUT ² kW	SENSIBLE CAPACITY ¹						TOTAL CAP. ¹ MBH	POWER INPUT ² kW	SENSIBLE CAPACITY ¹							
				ENTERING DRY BULB, °F								ENTERING DRY BULB, °F							
CFM	WB °F	86	83	80	77	74	71	68	86	83	80	77	74	71	68				
2000	72	51	4.9	40	35	29	24	-	-	-	49	5.2	39	34	29	23	-	-	-
	67	46	4.7	42	42	39	34	28	23	-	41	5.0	40	40	37	32	26	21	-
	62	43	4.6	43	43	42	37	32	27	21	40	4.9	40	40	39	34	29	23	18
	57	43	4.6	43	43	43	38	32	28	22	40	4.8	40	40	40	34	30	24	19
1800	72	50	4.8	38	33	28	23	-	-	-	47	5.1	37	32	27	22	-	-	-
	67	45	4.7	41	41	37	32	27	22	-	40	4.9	37	36	35	30	25	20	-
	62	42	4.6	42	42	41	37	32	27	22	39	4.8	39	39	37	34	29	24	19
	57	42	4.5	42	42	42	37	33	27	23	38	4.7	38	38	38	33	30	25	20
1600	72	49	4.8	35	31	26	22	-	-	-	46	5.1	34	29	25	20	-	-	-
	67	44	4.6	40	40	35	31	26	22	-	39	4.9	36	36	32	28	23	19	-
	62	41	4.5	41	41	40	35	32	27	23	37	4.7	37	37	36	33	28	24	19
	57	41	4.4	41	41	41	36	32	28	23	37	4.7	37	37	37	34	28	25	20
1400	72	47	4.7	32	28	24	20	-	-	-	44	5.0	31	27	23	19	-	-	-
	67	42	4.5	38	36	32	28	24	20	-	37	4.8	36	34	30	26	21	17	-
	62	39	4.4	39	38	37	33	28	25	20	36	4.7	36	35	34	30	26	22	18
	57	39	4.4	39	39	37	33	29	25	21	36	4.6	36	36	34	31	26	23	19
1200	72	44	4.6	28	25	21	18	-	-	-	42	4.9	28	24	21	17	-	-	-
	67	40	4.5	36	32	29	25	22	18	-	36	4.7	34	31	27	24	20	17	-
	62	38	4.4	38	36	34	29	27	22	20	35	4.6	35	34	30	28	24	20	17
	57	37	4.3	37	37	34	30	27	23	20	35	4.6	35	35	31	29	24	21	18

1. These capacities are gross ratings. For net capacity, determine the kW of the supply air blower motor from the SUPPLY AIR BLOWER PERFORMANCE Table, multiply this value by 3.415 MBH/kW to determine the motor heat, and deduct this heat from the gross capacity of the unit.

2. These ratings include the compressor and the condenser fan motors but not the supply air blower motor. The total condenser fan motor power input is 0.35kW. Refer to the SUPPLY AIR BLOWER PERFORMANCE Table for the kW of the supply air blower motor.

NOMINAL RATING

TABLE 5: BQ060 COOLING CAPACITIES (5 TON)

AIR ON EVAPORATOR COIL		TEMPERATURE OF AIR ON CONDENSER COIL																			
		85°F								95°F											
		TOTAL CAP. ¹ MBH	POWER INPUT ² kW	SENSIBLE CAPACITY ¹								TOTAL CAP. ¹ MBH	POWER INPUT ² kW	SENSIBLE CAPACITY ¹							
				ENTERING DRY BULB, °F										ENTERING DRY BULB, °F							
CFM	WB °F	86	83	80	77	74	71	68	86	83	80	77	74	71	68						
2500	72	68	5.7	51	44	38	31	-	-	-	67	6.0	51	45	38	31	-	-	-		
	67	65	5.6	58	56	50	43	37	30	-	64	5.9	56	56	50	43	37	30	-		
	62	61	5.6	61	61	59	53	46	39	33	59	5.9	59	59	57	50	44	38	31		
	57	60	5.5	60	60	59	53	47	40	33	58	5.8	58	58	57	51	44	39	32		
2250	72	67	5.6	48	42	36	30	-	-	-	66	5.9	48	42	36	30	-	-	-		
	67	64	5.6	57	54	48	42	36	30	-	63	5.9	55	54	48	42	35	29	-		
	62	60	5.5	60	60	57	51	45	39	33	57	5.8	57	57	55	50	44	38	32		
	57	59	5.5	59	59	58	52	46	40	34	57	5.8	57	57	56	50	45	39	33		
2000	72	66	5.6	45	40	34	29	-	-	-	65	5.9	45	40	34	29	-	-	-		
	67	63	5.5	56	51	45	40	35	29	-	61	5.9	55	51	45	40	34	29	-		
	62	59	5.4	59	59	55	50	44	39	33	56	5.8	56	56	54	49	44	38	33		
	57	58	5.4	58	58	57	52	46	41	36	56	5.7	56	56	55	50	44	39	34		
1750	72	64	5.5	42	37	32	27	-	-	-	62	5.9	43	38	33	28	-	-	-		
	67	61	5.5	52	47	42	37	33	28	-	59	5.8	53	48	44	39	34	29	-		
	62	57	5.4	57	56	51	46	41	37	32	54	5.7	54	54	52	48	43	38	33		
	57	57	5.4	57	57	53	48	44	39	34	54	5.7	54	54	53	49	43	39	34		
1500	72	62	5.5	38	34	30	25	-	-	-	60	5.8	41	36	32	28	-	-	-		
	67	59	5.5	48	43	39	35	31	26	-	57	5.8	51	46	42	38	34	29	-		
	62	55	5.4	55	52	47	43	39	35	30	52	5.7	52	52	50	46	42	38	34		
	57	55	5.3	55	54	49	45	41	37	32	52	5.6	52	52	51	47	42	39	35		

AIR ON EVAPORATOR COIL		TEMPERATURE OF AIR ON CONDENSER COIL																			
		105°F								115°F											
		TOTAL CAP. ¹ MBH	POWER INPUT ² kW	SENSIBLE CAPACITY ¹								TOTAL CAP. ¹ MBH	POWER INPUT ² kW	SENSIBLE CAPACITY ¹							
				ENTERING DRY BULB, °F										ENTERING DRY BULB, °F							
CFM	WB °F	86	83	80	77	74	71	68	86	83	80	77	74	71	68						
2500	72	64	6.0	51	44	38	31	-	-	-	60	6.9	50	43	37	30	-	-	-		
	67	59	5.9	51	51	49	42	36	29	-	54	6.6	54	53	47	41	34	27	-		
	62	54	5.9	54	54	51	46	40	33	26	49	6.5	49	49	48	42	35	28	22		
	57	54	5.8	54	54	52	46	41	33	26	49	6.5	49	49	49	43	35	28	23		
2250	72	63	5.9	48	42	36	30	-	-	-	60	6.8	47	41	35	29	-	-	-		
	67	58	5.9	51	51	46	40	34	28	-	54	6.6	47	47	45	39	32	26	-		
	62	53	5.8	53	53	52	46	40	34	28	49	6.5	49	49	47	42	36	30	24		
	57	53	5.8	53	53	52	46	41	35	27	49	6.4	49	49	48	43	37	31	25		
2000	72	62	5.9	45	39	34	28	-	-	-	59	6.8	44	38	33	27	-	-	-		
	67	57	5.9	51	49	44	38	33	27	-	53	6.5	45	45	42	36	31	26	-		
	62	52	5.8	52	52	51	46	40	35	30	48	6.4	48	48	46	42	36	31	25		
	57	52	5.7	52	52	51	46	40	36	31	47	6.4	47	47	46	43	36	32	25		
1750	72	60	5.9	41	37	32	27	-	-	-	56	6.7	40	35	30	25	-	-	-		
	67	55	5.8	48	46	41	36	31	26	-	51	6.5	43	43	38	33	29	24	-		
	62	50	5.7	50	50	48	43	39	34	29	46	6.4	46	46	43	38	33	28	24		
	57	50	5.7	50	50	48	43	39	34	30	45	6.3	45	45	43	38	33	28	25		
1500	72	57	5.8	38	34	30	25	-	-	-	53	6.6	36	31	27	23	-	-	-		
	67	53	5.8	47	43	38	34	30	26	-	48	6.4	41	39	35	30	26	22	-		
	62	48	5.7	48	48	45	41	37	32	28	44	6.3	44	44	39	35	30	26	22		
	57	48	5.6	48	48	45	41	38	32	28	43	6.2	43	43	40	36	30	26	23		

1. These capacities are gross ratings. For net capacity, determine the kW of the supply air blower motor from the SUPPLY AIR BLOWER PERFORMANCE Table, multiply this value by 3.415 MBH/kW to determine the motor heat, and deduct this heat from the gross capacity of the unit.
 2. These ratings include the compressor and the condenser fan motors but not the supply air blower motor. The total condenser fan motor power input is 0.35kW. Refer to the SUPPLY AIR BLOWER PERFORMANCE Table for the kW of the supply air blower motor.

NOMINAL RATING

TABLE 6: BQ HEATING CAPACITIES

Model Tonnage	CFM	RET. AIR °F	CAP & KW	OUTDOOR AIR TEMPERATURE, °F (72% RH)							
				-10	0	10	20	30	40	50	60
3	1750	55	MBH	13.1	16.4	23.5	29.1	30.2	41.7	47	48.2
			KW	2.9	3	3.2	3.3	3.5	3.7	3.8	3.9
		70	MBH	11.9	15	21.5	26.7	27.7	38.2	43.1	44.1
			KW	3	3.1	3.4	3.4	3.6	3.8	3.9	4.1
		80	MBH	10.9	13.6	19.6	24.3	25.2	34.8	39.3	40.2
			KW	3.1	3.2	3.4	3.5	3.8	3.9	4.1	4.2
	1400	55	MBH	12.4	15.5	22.5	27.7	28.7	39.6	44.7	45.8
			KW	2.7	2.9	3	3.1	3.3	3.5	3.6	3.7
		70	MBH	11.4	14.1	20.3	25.2	26.1	36.1	40.7	41.6
			KW	2.9	3	3.2	3.3	3.5	3.7	3.8	3.9
		80	MBH	10.4	13.1	18	23.2	24.2	33.3	37.6	38.5
			KW	3	3.1	3.2	3.4	3.6	3.8	3.9	4
	1200	55	MBH	11.8	14.8	21.3	26.5	27.5	37.8	42.7	43.7
			KW	2.7	2.8	3	3.1	3.3	3.4	3.5	3.6
		70	MBH	10.8	13.5	19.4	24	24.9	34.4	38.8	39.7
			KW	2.9	3	3.1	3.3	3.4	3.6	3.7	3.8
		80	MBH	9.9	12.4	17.8	22	22.9	31.5	35.6	36.5
			KW	2.9	3.1	3.2	3.4	3.5	3.7	3.8	3.9
1050	55	MBH	11.2	14.1	20.3	25.2	26.1	35.9	40.6	41.6	
		KW	2.6	2.7	2.9	3	3.3	3.3	3.5	3.5	
	70	MBH	10.2	12.8	18.5	22.8	23.6	32.7	36.9	37.8	
		KW	2.8	2.9	3	3.2	3.3	3.5	3.6	3.7	
	80	MBH	9.3	11.7	16.7	20.7	21.5	29.8	33.6	34.4	
		KW	2.8	3	3.1	3.3	3.4	3.6	3.7	3.8	
4	2000	55	MBH	12.3	17.3	22.5	28.2	36.3	44.5	53.8	61.6
			KW	3.4	3.5	3.6	3.6	3.8	4	4.6	5.2
		70	MBH	11.8	16.6	21.6	27.1	34.9	42.8	51.7	59.2
			KW	3.5	3.6	3.8	3.8	4	4.2	4.8	5.4
		80	MBH	10.9	15.3	19.9	24.9	32.1	39.4	47.6	54.5
			KW	3.6	3.7	4	4	4.1	4.4	5	5.7
	1600	55	MBH	12.1	17	22	27.7	34.5	42.3	51.2	58.6
			KW	3.3	3.4	3.5	3.6	3.6	3.8	4.4	5
		70	MBH	11.6	16.3	21.2	26.6	33.2	40.7	49.2	56.3
			KW	3.4	3.5	3.6	3.7	3.8	4	4.6	5.2
		80	MBH	10.7	15	19.5	24.5	30.5	37.4	45.3	51.8
			KW	3.5	3.6	3.8	3.9	4	4.2	4.8	5.4
	1200	55	MBH	10.9	15.3	19.9	24.9	31.7	38.9	47	53.8
			KW	3.1	3.2	3.3	3.4	3.5	3.7	4.2	4.8
		70	MBH	10.5	14.7	19.1	24	30.5	37.4	45.2	51.7
			KW	3.2	3.3	3.4	3.5	3.6	3.8	4.4	5
		80	MBH	9.6	13.5	17.6	22	28.1	34.4	41.6	47.6
			KW	3.3	3.4	3.5	3.6	3.8	4	4.6	5.2
5	2500	55	MBH	18.2	24.7	31.1	38.4	45.6	55.4	64.7	75.6
			KW	5	5.1	5.2	5.3	5.3	5.6	5.9	6.5
		70	MBH	17.5	23.7	29.9	37	43.9	53.3	62.2	72.7
			KW	5.2	5.3	5.4	5.5	5.6	5.9	6.2	6.8
		80	MBH	16.1	21.8	27.5	34	40.4	49	57.2	66.9
			KW	5.4	5.6	5.7	5.8	5.9	6	6.5	7.2
	2000	55	MBH	18	24.4	30.8	38.1	45	54.7	63.9	74.7
			KW	4.7	4.8	4.9	5	5.3	5.5	5.8	6.4
		70	MBH	17.3	23.5	29.6	36.6	43.3	52.6	61.4	71.8
			KW	4.9	5	5.1	5.2	5.5	5.8	6.1	6.7
		80	MBH	15.9	21.6	27.2	33.7	39.8	48.4	56.5	66.1
			KW	5.1	5.3	5.4	5.5	5.8	6.1	6.4	7
	1500	55	MBH	16.2	22	27.8	34.3	41.4	50.2	58.7	68.6
			KW	4.5	4.6	4.7	4.8	5	5.3	5.5	6.1
		70	MBH	15.6	21.2	26.7	33	39.8	48.3	56.4	66
			KW	4.7	4.8	4.9	5	5.2	5.5	5.8	6.4
		80	MBH	14.4	19.5	24.6	30.4	36.6	44.5	51.9	60.7
			KW	4.9	5	5.1	5.2	5.5	5.8	6.1	6.7

TABLE 7: SUPPLY AIR BLOWER PERFORMANCE (3 TON BELT DRIVE) - SIDE DUCT APPLICATION

UNIT TONNAGE	AIR FLOW CFM	AVAILABLE EXTERNAL STATIC PRESSURE-IWG ³													
		0.20		0.30		0.40		0.50		0.60		0.70		0.80	
		RPM	WATTS	RPM	WATTS	RPM	WATTS	RPM	WATTS	RPM	WATTS	RPM	WATTS	RPM	WATTS
3 ^{1,2}	2000	843	860	880	925	919	1005	956	1065	993	1145	1030	1195	1067	1235
	1900	817	775	854	850	893	920	930	995	970	1065	1008	1125	1046	1170
	1800	790	700	828	760	867	840	906	905	944	980	985	1040	1025	1100
	1700	-	-	802	670	840	745	881	815	920	900	961	970	1001	1030
	1600	-	-	-	-	818	665	858	740	898	820	940	890	980	950
	1500	-	-	-	-	-	-	842	695	882	755	922	835	962	895
	1400	-	-	-	-	-	-	833	650	867	705	904	765	942	820
	1300	-	-	-	-	-	-	-	-	858	665	893	725	932	785
1200	-	-	-	-	-	-	-	-	847	640	880	680	916	730	

UNIT TONNAGE	AIR FLOW CFM	AVAILABLE EXTERNAL STATIC PRESSURE-IWG ³													
		0.90		1.00		1.10		1.20		1.30		1.40		1.50	
		RPM	WATTS	RPM	WATTS	RPM	WATTS	RPM	WATTS	RPM	WATTS	RPM	WATTS	RPM	WATTS
3 ^{1,2}	2000	1103	1270	-	-	-	-	-	-	-	-	-	-	-	-
	1900	1085	1210	-	-	-	-	-	-	-	-	-	-	-	-
	1800	1064	1145	1102	1180	-	-	-	-	-	-	-	-	-	-
	1700	1040	1075	1081	1115	1121	1140	-	-	-	-	-	-	-	-
	1600	1020	1005	1060	1050	1100	1085	-	-	-	-	-	-	-	-
	1500	1003	945	1044	995	1086	1035	-	-	-	-	-	-	-	-
	1400	982	880	1024	920	1067	965	1107	1000	-	-	-	-	-	-
	1300	970	835	1010	870	1053	920	1099	960	-	-	-	-	-	-
1200	953	780	992	815	1034	855	1080	905	-	-	-	-	-	-	

1. 230/460/575 Volts

2. For 208 Volts multiply values by 0.95.

3. Includes allowances for a wet evaporator coil, 1" filters, and the heat exchangers. Refer to STATIC RESISTANCE Table for resistance values on applications other than gas / electric units with side duct airflows.

TABLE 8: SUPPLY AIR BLOWER PERFORMANCE (4 TON BELT DRIVE) - SIDE DUCT APPLICATION

UNIT TONNAGE	AIR FLOW CFM	AVAILABLE EXTERNAL STATIC PRESSURE-IWG ³													
		0.20		0.30		0.40		0.50		0.60		0.70		0.80	
		RPM	WATTS	RPM	WATTS	RPM	WATTS	RPM	WATTS	RPM	WATTS	RPM	WATTS	RPM	WATTS
4 ^{1,2}	2000	843	860	880	925	919	1005	956	1065	993	1145	1030	1195	1067	1235
	1900	817	775	854	850	893	920	930	995	970	1065	1008	1125	1046	1170
	1800	790	700	828	760	867	840	906	905	944	980	985	1040	1025	1100
	1700	-	-	802	670	840	745	881	815	920	900	961	970	1001	1030
	1600	-	-	-	-	818	665	858	740	898	820	940	890	980	950
	1500	-	-	-	-	-	-	842	695	882	755	922	835	962	895
	1400	-	-	-	-	-	-	833	650	867	705	904	765	942	820
	1300	-	-	-	-	-	-	-	-	858	665	893	725	932	785
1200	-	-	-	-	-	-	-	-	847	640	880	680	916	730	

UNIT TONNAGE	AIR FLOW CFM	AVAILABLE EXTERNAL STATIC PRESSURE-IWG ³													
		0.90		1.00		1.10		1.20		1.30		1.40		1.50	
		RPM	WATTS	RPM	WATTS	RPM	WATTS	RPM	WATTS	RPM	WATTS	RPM	WATTS	RPM	WATTS
4 ^{1,2}	2000	1103	1270	-	-	-	-	-	-	-	-	-	-	-	-
	1900	1085	1210	-	-	-	-	-	-	-	-	-	-	-	-
	1800	1064	1145	1102	1180	-	-	-	-	-	-	-	-	-	-
	1700	1040	1075	1081	1115	1121	1140	-	-	-	-	-	-	-	-
	1600	1020	1005	1060	1050	1100	1085	-	-	-	-	-	-	-	-
	1500	1003	945	1044	995	1086	1035	-	-	-	-	-	-	-	-
	1400	982	880	1024	920	1067	965	1107	1000	-	-	-	-	-	-
	1300	970	835	1010	870	1053	920	1099	960	-	-	-	-	-	-
1200	953	780	992	815	1034	855	1080	905	-	-	-	-	-	-	

1. 230/460/575 Volts

2. For 208 Volts multiply values by 0.95.

3. Includes allowances for a wet evaporator coil, 1" filters, and the heat exchangers. Refer to STATIC RESISTANCE Table for resistance values on applications other than gas / electric units with side duct airflows.

TABLE 9: SUPPLY AIR BLOWER PERFORMANCE (5 TON BELT DRIVE) - SIDE DUCT APPLICATION

UNIT TONNAGE	AIR FLOW CFM	AVAILABLE EXTERNAL STATIC PRESSURE-IWG ³													
		0.20		0.30		0.40		0.50		0.60		0.70		0.80	
		RPM	WATTS	RPM	WATTS	RPM	WATTS	RPM	WATTS	RPM	WATTS	RPM	WATTS	RPM	WATTS
5 ^{1,2}	2500	1059	1560	1077	1590	1095	1630	1114	1650	1134	1660	1158	1685	1181	1720
	2400	1032	1405	1054	1470	1074	1525	1094	1560	1116	1595	1140	1620	1167	1640
	2300	1005	1260	1024	1275	1049	1370	1069	1440	1090	1475	1116	1505	1142	1535
	2200	980	1160	1002	1170	1022	1190	1044	1250	1066	1350	1090	1410	1117	1440
	2100	930	1060	957	1070	983	1080	1010	1100	1039	1160	1064	1260	1092	1340
	2000	877	950	908	975	941	1000	976	1020	1009	1050	1040	1100	1070	1225
	1900	-	-	-	-	894	885	940	940	980	980	1014	1020	1047	1095
	1800	-	-	-	-	855	815	903	860	950	905	988	940	1022	970
	1700	-	-	-	-	-	-	884	815	925	850	964	880	1001	910
	1600	-	-	-	-	-	-	864	770	908	805	948	835	987	870
1500	-	-	-	-	-	-	-	-	882	740	926	780	965	830	

UNIT TONNAGE	AIR FLOW CFM	AVAILABLE EXTERNAL STATIC PRESSURE-IWG ³													
		0.90		1.00		1.10		1.20		1.30		1.40		1.50	
		RPM	WATTS	RPM	WATTS	RPM	WATTS	RPM	WATTS	RPM	WATTS	RPM	WATTS	RPM	WATTS
5 ^{1,2}	2500	-	-	-	-	-	-	-	-	-	-	-	-	-	-
	2400	1193	1665	-	-	-	-	-	-	-	-	-	-	-	-
	2300	1170	1580	1202	1620	-	-	-	-	-	-	-	-	-	-
	2200	1148	1480	1180	1530	-	-	-	-	-	-	-	-	-	-
	2100	1121	1385	1155	1425	1190	1475	-	-	-	-	-	-	-	-
	2000	1100	1285	1133	1340	1169	1385	1205	1445	-	-	-	-	-	-
	1900	1079	1180	1110	1240	1143	1280	1178	1330	1222	1375	-	-	-	-
	1800	1058	1060	1090	1135	1122	1190	1158	1240	1196	1295	-	-	-	-
	1700	1035	960	1071	1030	1103	1100	1134	1140	1164	1175	1197	1205	-	-
	1600	1020	900	1056	965	1088	1035	1118	1065	1145	1105	1170	1130	1198	1150
1500	1004	860	1038	880	1070	925	1101	980	1130	1045	1158	1075	1184	1110	

1. 230/460/575 Volts

2. For 208 Volts multiply values by 0.95.

3. Includes allowances for a wet evaporator coil, 1" filters, and the heat exchangers. Refer to STATIC RESISTANCE Table for resistance values on applications other than gas / electric units with side duct airflows.

TABLE 10: SUPPLY AIR BLOWER PERFORMANCE (3 - 5 TON DIRECT DRIVE) - SIDE DUCT APPLICATION

UNIT TONNAGE	MOTOR SPEED	AVAILABLE EXTERNAL STATIC PRESSURE-IWG ²									
		0.20		0.30		0.40		0.50		0.60	
		CFM	WATTS	CFM	WATTS	CFM	WATTS	CFM	WATTS	CFM	WATTS
3 ¹	HI	-	-	-	-	-	-	1720	825	1665	795
	MED	1660	850	1630	820	1590	780	1550	750	1500	720
	LOW	1470	750	1440	725	1410	700	1370	675	1330	650
4 ¹	HI	-	-	-	-	2000	1010	1950	975	1905	945
	MED	1810	910	1780	880	1740	850	1700	825	1665	800
	LOW	1635	810	1610	780	1580	760	1555	740	1540	730
5 ¹	HI	-	-	-	-	2500	1400	2420	1350	2340	1300
	MED	2390	1350	2350	1300	2300	1255	2245	1210	2190	1165
	LOW	2270	1320	2230	1270	2190	1220	2145	1170	2090	1110

UNIT TONNAGE	MOTOR SPEED	AVAILABLE EXTERNAL STATIC PRESSURE-IWG ²							
		0.70		0.80		0.90		1.00	
		CFM	WATTS	CFM	WATTS	CFM	WATTS	CFM	WATTS
3 ¹	HI	1600	765	1540	735	1490	700	1380	670
	MED	1450	690	1400	665	1360	650	1270	610
	LOW	1290	625	1250	610	1220	600	1130	560
4 ¹	HI	1840	910	1770	825	1660	825	1530	775
	MED	1620	775	1560	740	1480	700	1390	660
	LOW	1510	715	1460	690	1400	660	1300	615
5 ¹	HI	2260	1250	2160	1190	2060	1135	1925	1065
	MED	2130	1120	2065	1075	1990	1030	1900	970
	LOW	2030	1070	1960	1020	1890	970	1810	920

1. Side Duct application (230/460/575 Volts)

2. Includes allowances for a wet evaporator coil, 1" filters, and the heat exchangers. Refer to STATIC RESISTANCES Table for resistance values.

TABLE 11: BELT DRIVE BLOWER MOTOR AND DRIVE DATA

MODEL SIZE	BLOWER RANGE (RPM)	MOTOR ¹		ADJUSTABLE MOTOR PULLEY				FIXED BLOWER PULLEY				BELT (NOTCHED)		
		HP	FRAME	DESIG- NATION	OUTSIDE DIA. (IN.)	PITCH DIA. (IN.)	BORE (IN.)	DESIG- NATION	OUTSIDE DIA. (IN.)	PITCH DIA. (IN.)	BORE (IN.)	DESIG- NATION	PITCH LENGTH (IN.)	QTY.
3 TON	790/1120	1 1/2	56	1VL40	2.7-3.7	2.4-3.4	5/8	AK61	5.9	5.7	1	A36	37.3	1
4 TON	790/1120	1 1/2	56	1VL40	2.7-3.7	2.4-3.4	5/8	AK61	5.9	5.7	1	A36	37.3	1
5 TON	850/1220	1 1/2	56	1VL40	2.7-3.7	2.4-3.4	5/8	AK56	5.4	5.2	1	A36	37.3	1

1. All motors have solid bases and are inherently protected. these motors can be selected to operate into their service factor because they are located in the moving air, upstream of any heating device.

TABLE 12: STATIC RESISTANCES

DESCRIPTION		RESISTANCE, IWG								
		CFM								
		1000	1200	1400	1600	1800	2000	2200	2400	2600
ECONOMIZER ^{1,2}		0.07	0.08	0.09	0.11	0.13	0.15	0.17	0.20	0.23
ELECTRIC HEATERS ¹	5-15KW	0.04	0.05	0.06	0.07	0.08	0.10	0.12	0.14	0.16
	20-30KW	0.06	0.07	0.08	0.09	0.11	0.13	0.15	0.17	0.20
BOTTOM DUCT CONNECTIONS ¹		0.06	0.07	0.08	0.09	0.10	0.11	0.12	0.14	0.16

1. Deduct these resistance values from the available external static pressure shown in SUPPLY AIR BLOWER PERFORMANCE Tables.
2. The pressure through the economizer is greater for 100% outdoor air than for 100% return air. If the resistance of the return air duct system is less than 0.25 IWG, the unit will deliver less CFM during full economizer operation.

TABLE 13: ELECTRIC HEATER CFM LIMITATIONS

UNIT MODEL SIZE NOMINAL TONS	VOLTAGE	MINIMUM SUPPLY AIR CFM					
		HEATER SIZE NOMINAL KW					
		5	7	10	15	20	30
3	208/230-1-60	1100	1100	1200	1200	1300	-
	208/230-3-60	1100	1100	1200	1200	1300	-
	460-3-60	-	1100	1200	1200	1300	-
	575-3-60	-	-	1200	1200	1300	-
4	208/230-1-60	1300	1300	1300	1300	1300	-
	208/230-3-60	1300	1300	1300	1300	1300	-
	460-3-60	-	1300	1300	1300	1300	-
	575-3-60	-	-	1300	1300	1400	-
5	208/230-1-60	1600	1600	1600	1600	1600	1600
	208/230-3-60	1600	1600	1600	1600	1600	1600
	460-3-60	-	1600	1600	1600	1600	1600
	575-3-60	-	-	1600	1600	1600	1800

TABLE 14: ELECTRICAL DATA - BQ036 & 048 DIRECT DRIVE WITHOUT POWR'D CONVENIENCE OUTLET

Model Tonnage	Voltage	Compressors		OD Fan Motor FLA	ID Blower Motor FLA	Conv Outlet Amps	Electric Heater Model No.	Heater kW	Heater Amps	Minimum Circuit Ampacity	Max Fuse / BRKR ¹ Size Amps
		RLA Each	LRA Each								
3	208-1-60	19.0	105	1.7	4.4	0.0	NONE	0.0	0.0	29.9	45
							2CE04510506	4.0	19.2	53.9	60
							2CE04510706	5.6	26.9	63.5	70
							2CE04511006	8.0	38.5	77.9	80
							2CE04511506	11.9	57.2	101.4	110
							2CE04512006	15.9	76.4	125.4	150
	230-1-60	19.0	105	1.7	4.4	0.0	NONE	0.0	0.0	29.9	45
							2CE04510506	5.3	22.1	57.5	70
							2CE04510706	7.5	31.3	68.9	80
							2CE04511006	10.6	44.2	85.1	90
							2CE04511506	15.9	66.3	112.7	125
							2CE04512006	21.2	88.3	140.3	150
	208-3-60	11.9	85	1.7	4.4	0.0	NONE	0.0	0.0	21.0	30
							2CE04510525 ²	4.0	11.1	34.9	40
							2CE04510725 ²	5.6	15.5	40.4	45
							2CE04511025	8.0	22.2	48.7	50
							2CE04511525	11.9	33.0	62.3	70
							2CE04512025	15.9	44.1	76.1	80
230-3-60	11.9	85	1.7	4.4	0.0	NONE	0.0	0.0	21.0	30	
						2CE04510525 ²	5.3	12.7	36.9	45	
						2CE04510725 ²	7.5	18.0	43.5	50	
						2CE04511025	10.6	25.5	52.8	60	
						2CE04511525	15.9	38.2	68.8	70	
						2CE04512025	21.2	51.0	84.7	90	
460-3-60	5.9	42	1.0	2.2	0.0	NONE	0.0	0.0	10.6	15	
						2CE04510746 ²	6.8	8.2	20.8	25	
						2CE04511046 ²	10.1	12.1	25.8	30	
						2CE04511546 ²	13.6	16.4	31.0	35	
						2CE04512046 ²	19.5	23.5	39.9	40	
						NONE	0.0	0.0	8.6	15	
575-3-60	4.8	34	1	2.2	0.0	2CE04511058	10.6	10.2	21.3	25	
						2CE04511558	15.9	15.3	27.7	30	
						2CE04512058	21.2	20.4	34.1	35	
						NONE	0.0	0.0	38.6	60	
						2CE04510506	4.0	19.2	62.6	80	
						2CE04510706	5.6	26.9	72.2	90	
4	208-1-60	25.0	105	2.3	5.0	0.0	NONE	0.0	0.0	38.6	60
							2CE04510506	4.0	19.2	62.6	80
							2CE04510706	5.6	26.9	72.2	90
							2CE04511006	8.0	38.5	86.6	100
							2CE04511506	11.9	57.2	110.1	125
							2CE04512006	15.9	76.4	134.0	150
	230-1-60	25.0	105	2.3	5.0	0.0	NONE	0.0	0.0	38.6	60
							2CE04510506	5.3	22.1	66.2	80
							2CE04510706	7.5	31.3	77.6	90
							2CE04511006	10.6	44.2	93.8	100
							2CE04511506	15.9	66.3	121.4	125
							2CE04512006	21.2	88.3	149.0	150
	208-3-60	14.7	130	2.3	5.0	0.0	NONE	0.0	0.0	25.7	40
							2CE04510525 ²	4.0	11.1	39.6	50
							2CE04510725 ²	5.6	15.5	45.1	50
							2CE04511025	8.0	22.2	53.4	60
							2CE04511525	11.9	33.0	67.0	70
							2CE04512025	15.9	44.1	80.8	90
230-3-60	14.7	130	2.3	5.0	0.0	NONE	0.0	0.0	25.7	40	
						2CE04510525 ²	5.3	12.7	41.6	50	
						2CE04510725 ²	7.5	18.0	48.2	50	
						2CE04511025	10.6	25.5	57.5	60	
						2CE04511525	15.9	38.2	73.5	80	
						2CE04512025	21.2	51.0	89.4	90	
460-3-60	7.7	64	1.3	2.2	0.0	NONE	0.0	0.0	12.4	15	
						2CE04510746 ²	6.8	8.2	22.6	25	
						2CE04511046 ²	10.1	12.1	27.6	30	
						2CE04511546 ²	13.6	16.4	32.8	35	
						2CE04512046 ²	19.5	23.5	41.7	45	
						NONE	0.0	0.0	10.8	15	
575-3-60	6.4	52	1.3	2.2	0.0	2CE04511058	10.6	10.2	24.4	25	
						2CE04511558	15.9	15.3	30.7	35	
						2CE04512058	21.2	20.4	37.1	40	
						NONE	0.0	0.0	38.6	60	
						2CE04510506	4.0	19.2	62.6	80	
						2CE04510706	5.6	26.9	72.2	90	

1. HACR Type per NEC.

2. These electric heaters DO NOT include a fuse box. If a fuse box is required to meet a local code (i.e. Chicago), the fuse block accessories 2FB04700825 and 2FB04700846 are available for field installation.

TABLE 15: ELECTRICAL DATA - BQ060 DIRECT DRIVE WITHOUT POWR'D CONVENIENCE OUTLET

Model Tonnage	Voltage	Compressors		OD Fan Motor FLA	ID Blower Motor FLA	Conv Outlet Amps	Electric Heater Model No.	Heater kW	Heater Amps	Minimum Circuit Ampacity Amps	Max Fuse / BRKR ¹ Size Amps
		RLA Each	LRA Each								
5	208-1-60	32.1	148	2.3	6.6	0.0	NONE	0.0	0.0	49.0	80
							2CE04510506	4.0	19.2	73.1	100
							2CE04510706	5.6	26.9	82.7	100
							2CE04511006	8.0	38.5	97.1	110
							2CE04511506	11.9	57.2	120.5	125
							2CE04512006	15.9	76.4	144.6	150
	2CE04513006	22.2	106.7	182.4	200						
	230-1-60	32.1	148	2.3	6.6	0.0	NONE	0.0	0.0	49.0	80
							2CE04510506	5.3	22.1	76.6	100
							2CE04510706	7.5	31.3	88.1	110
							2CE04511006	10.6	44.2	104.2	125
							2CE04511506	15.9	66.3	131.8	150
							2CE04512006	21.2	88.3	159.4	175
	2CE04513006	29.6	123.3	203.2	225						
	208-3-60	19.3	137	2.3	6.6	0.0	NONE	0.0	0.0	33.0	50
							2CE04510525 ²	4.0	11.1	46.9	60
							2CE04510725 ²	5.6	15.5	52.5	60
							2CE04511025	8.0	22.2	60.8	70
							2CE04511525	11.9	33.0	74.3	80
							2CE04512025	15.9	44.1	88.2	90
	2CE04513025	22.2	61.6	110.1	125						
	230-3-60	19.3	137	2.3	6.6	0.0	NONE	0.0	0.0	33.0	50
							2CE04510525 ²	5.3	12.7	49.0	60
							2CE04510725 ²	7.5	18.0	55.6	70
2CE04511025							10.6	25.5	64.9	70	
2CE04511525							15.9	38.2	80.8	90	
2CE04512025							21.2	51.0	96.8	100	
2CE04513025	29.6	71.2	122.0	125							
460-3-60	10.0	62	1.3	3.3	0.0	NONE	0.0	0.0	17.1	25	
						2CE04510746 ²	6.8	8.2	27.3	35	
						2CE04511046 ²	10.1	12.1	32.3	35	
						2CE04511546 ²	13.6	16.4	37.5	40	
						2CE04512046 ²	19.5	23.5	46.4	50	
						2CE04513046 ²	28.8	34.6	60.4	70	
575-3-60	7.9	50	1.3	3.3	0.0	NONE	0.0	0.0	13.6	20	
						2CE04511058	10.6	10.2	26.3	30	
						2CE04511558	15.9	15.3	32.7	35	
						2CE04512058	21.2	20.4	39.1	40	
						2CE04513058	30.4	29.3	50.1	60	

1. HACR Type per NEC.

2. These electric heaters DO NOT include a fuse box. If a fuse box is required to meet a local code (i.e. Chicago), the fuse block accessories 2FB04700825 and 2FB04700846 are available for field installation.

TABLE 16: ELECTRICAL DATA - BQ036 & 048 BELT DRIVE WITHOUT POWR'D CONVENIENCE OUTLET

Model Tonnage	Voltage	Compressors		OD Fan Motor FLA	ID Blower Motor FLA	Conv Outlet Amps	Electric Heater Model No.	Heater kW	Heater Amps	Minimum Circuit Ampacity Amps	Max Fuse / BRKR ¹ Size Amps
		RLA Each	LRA Each								
3	208-1-60	19.0	105	1.7	7.6	0.0	NONE	0.0	0.0	33.0	50
							2CE04510506	4.0	19.2	57.1	70
							2CE04510706	5.6	26.9	66.7	70
							2CE04511006	8.0	38.5	81.1	90
							2CE04511506	11.9	57.2	104.6	110
							2CE04512006	15.9	76.4	128.6	150
	230-1-60	19.0	105	1.7	7.6	0.0	NONE	0.0	0.0	33.0	50
							2CE04510506	5.3	22.1	60.7	70
							2CE04510706	7.5	31.3	72.1	80
							2CE04511006	10.6	44.2	88.3	90
							2CE04511506	15.9	66.3	115.9	125
							2CE04512006	21.2	88.3	143.5	150
	208-3-60	11.9	85	1.7	5.2	0.0	NONE	0.0	0.0	21.8	30
							2CE04510525 ²	4.0	11.1	35.7	40
							2CE04510725 ²	5.6	15.5	41.2	45
							2CE04511025	8.0	22.2	49.5	50
							2CE04511525	11.9	33.0	63.1	70
							2CE04512025	15.9	44.1	76.9	80
230-3-60	11.9	85	1.7	5.2	0.0	NONE	0.0	0.0	21.8	30	
						2CE04510525 ²	5.3	12.7	37.7	45	
						2CE04510725 ²	7.5	18.0	44.3	50	
						2CE04511025	10.6	25.5	53.6	60	
						2CE04511525	15.9	38.2	69.6	70	
						2CE04512025	21.2	51.0	85.5	90	
460-3-60	5.9	42	1.0	2.6	0.0	NONE	0.0	0.0	11.0	15	
						2CE04510746 ²	6.8	8.2	21.2	25	
						2CE04511046 ²	10.1	12.1	26.2	30	
						2CE04511546 ²	13.6	16.4	31.4	35	
						2CE04512046 ²	19.5	23.5	40.3	45	
						2CE04512058	21.2	20.4	33.9	35	
4	208-1-60	25.0	105	2.3	7.6	0.0	NONE	0.0	0.0	41.2	60
							2CE04510506	4.0	19.2	65.2	80
							2CE04510706	5.6	26.9	74.8	90
							2CE04511006	8.0	38.5	89.2	100
							2CE04511506	11.9	57.2	112.7	125
							2CE04512006	15.9	76.4	136.7	150
	230-1-60	25.0	105	2.3	7.6	0.0	NONE	0.0	0.0	38.8	60
							2CE04510506	5.3	22.1	66.4	80
							2CE04510706	7.5	31.3	77.8	90
							2CE04511006	10.6	44.2	94.0	100
							2CE04511506	15.9	66.3	121.6	125
							2CE04512006	21.2	88.3	149.2	150
	208-3-60	14.7	130	2.3	5.2	0.0	NONE	0.0	0.0	25.9	40
							2CE04510525 ²	4.0	11.1	39.8	50
							2CE04510725 ²	5.6	15.5	45.3	50
							2CE04511025	8.0	22.2	53.6	60
							2CE04511525	11.9	33.0	67.2	70
							2CE04512025	15.9	44.1	81.0	90
230-3-60	14.7	130	2.3	5.2	0.0	NONE	0.0	0.0	25.9	40	
						2CE04510525 ²	5.3	12.7	41.8	50	
						2CE04510725 ²	7.5	18.0	48.4	50	
						2CE04511025	10.6	25.5	57.7	60	
						2CE04511525	15.9	38.2	73.7	80	
						2CE04512025	21.2	51.0	89.6	90	
460-3-60	7.7	64	1.3	2.6	0.0	NONE	0.0	0.0	12.8	15	
						2CE04510746 ²	6.8	8.2	23.0	25	
						2CE04511046 ²	10.1	12.1	28.0	30	
						2CE04511546 ²	13.6	16.4	33.2	35	
						2CE04512046 ²	19.5	23.5	42.1	45	
						2CE04512058	21.2	20.4	36.9	40	

1. HACR Type per NEC.

2. These electric heaters DO NOT include a fuse box. If a fuse box is required to meet a local code (i.e. Chicago), the fuse block accessories 2FB04700825 and 2FB04700846 are available for field installation.

TABLE 17: ELECTRICAL DATA - BQ060 BELT DRIVE WITHOUT POWR'D CONVENIENCE OUTLET

Model Tonnage	Voltage	Compressors		OD Fan Motor FLA	ID Blower Motor FLA	Conv Outlet Amps	Electric Heater Model No.	Heater kW	Heater Amps	Minimum Circuit Ampacity Amps	Max Fuse / BRKR ¹ Size Amps
		RLA Each	LRA Each								
5	208-1-60	32.1	148	2.3	7.6	0.0	NONE	0.0	0.0	50.0	80
							2CE04510506	4.0	19.2	74.1	100
							2CE04510706	5.6	26.9	83.7	100
							2CE04511006	8.0	38.5	98.1	110
							2CE04511506	11.9	57.2	121.5	125
							2CE04512006	15.9	76.4	145.6	150
	2CE04513006	22.2	106.7	183.4	200						
	230-1-60	32.1	148	2.3	7.6	0.0	NONE	0.0	0.0	50.0	80
							2CE04510506	5.3	22.1	77.6	100
							2CE04510706	7.5	31.3	89.1	110
							2CE04511006	10.6	44.2	105.2	125
							2CE04511506	15.9	66.3	132.8	150
							2CE04512006	21.2	88.3	160.4	175
	2CE04513006	29.6	123.3	204.2	225						
	208-3-60	19.3	137	2.3	5.2	0.0	NONE	0.0	0.0	31.6	50
							2CE04510525 ²	4.0	11.1	45.5	60
							2CE04510725 ²	5.6	15.5	51.1	60
							2CE04511025	8.0	22.2	59.4	70
							2CE04511525	11.9	33.0	72.9	80
							2CE04512025	15.9	44.1	86.8	90
	2CE04513025	22.2	61.6	108.7	110						
	230-3-60	19.3	137	2.3	5.2	0.0	NONE	0.0	0.0	31.6	50
							2CE04510525 ²	5.3	12.7	47.6	60
							2CE04510725 ²	7.5	18.0	54.2	60
2CE04511025							10.6	25.5	63.5	70	
2CE04511525							15.9	38.2	79.4	80	
2CE04512025							21.2	51.0	95.4	100	
2CE04513025	29.6	71.2	120.6	125							
460-3-60	10.0	62	1.3	2.6	0.0	NONE	0.0	0.0	16.4	25	
						2CE04510746 ²	6.8	8.2	26.6	30	
						2CE04511046 ²	10.1	12.1	31.6	35	
						2CE04511546 ²	13.6	16.4	36.8	40	
						2CE04512046 ²	19.5	23.5	45.7	50	
						2CE04513046 ²	28.8	34.6	59.7	60	
575-3-60	7.9	50	1.3	2	0.0	NONE	0.0	0.0	12.5	20	
						2CE04511058	10.6	10.2	25.3	30	
						2CE04511558	15.9	15.3	31.6	35	
						2CE04512058	21.2	20.4	38.0	40	
						2CE04513058	30.4	29.3	49.1	50	

1. HACR Type per NEC.

2. These electric heaters DO NOT include a fuse box. If a fuse box is required to meet a local code (i.e. Chicago), the fuse block accessories 2FB04700825 and 2FB04700846 are available for field installation.

TABLE 18: ELECTRICAL DATA - BQ036 & 048 DIRECT DRIVE WITH POWR'D CONVENIENCE OUTLET

Model Tonnage	Voltage	Compressors		OD Fan Motor FLA	ID Blower Motor FLA	Conv Outlet Amps	Electric Heater Model No.	Heater kW	Heater Amps	Minimum Circuit Ampacity Amps	Max Fuse / BRKR ¹ Size Amps
		RLA Each	LRA Each								
3	208-1-60	19.0	105	1.7	4.4	10.0	NONE	0.0	0.0	39.8	50
							2CE04510506	4.0	19.2	63.9	70
							2CE04510706	5.6	26.9	73.5	80
							2CE04511006	8.0	38.5	87.9	90
							2CE04511506	11.9	57.2	111.4	125
	2CE04512006	15.9	76.4	135.4	150						
	230-1-60	19.0	105	1.7	4.4	10.0	NONE	0.0	0.0	39.8	50
							2CE04510506	5.3	22.1	67.5	80
							2CE04510706	7.5	31.3	78.9	90
							2CE04511006	10.6	44.2	95.1	100
							2CE04511506	15.9	66.3	122.7	125
	2CE04512006	21.2	88.3	150.3	175						
	208-3-60	11.9	85	1.7	4.4	10.0	NONE	0.0	0.0	31.0	40
							2CE04510525 ²	4.0	11.1	44.9	50
							2CE04510725 ²	5.6	15.5	50.4	60
							2CE04511025	8.0	22.2	58.7	60
							2CE04511525	11.9	33.0	72.3	80
	2CE04512025	15.9	44.1	86.1	90						
	230-3-60	11.9	85	1.7	4.4	10.0	NONE	0.0	0.0	31.0	40
							2CE04510525 ²	5.3	12.7	46.9	50
							2CE04510725 ²	7.5	18.0	53.5	60
							2CE04511025	10.6	25.5	62.8	70
							2CE04511525	15.9	38.2	78.8	80
	2CE04512025	21.2	51.0	94.7	100						
460-3-60	5.9	42	1.0	2.2	5.0	NONE	0.0	0.0	15.6	20	
						2CE04510746 ²	6.8	8.2	25.8	30	
						2CE04511046 ²	10.1	12.1	30.8	35	
						2CE04511546 ²	13.6	16.4	36.0	40	
						2CE04512046 ²	19.5	23.5	44.9	45	
575-3-60	4.8	34	1	2.2	4.0	NONE	0.0	0.0	12.6	15	
						2CE04511058	10.6	10.2	25.3	30	
						2CE04511558	15.9	15.3	31.7	35	
2CE04512058	21.2	20.4	38.1	40							
4	208-1-60	25.0	105	2.3	5.0	10.0	NONE	0.0	0.0	48.6	70
							2CE04510506	4.0	19.2	72.6	90
							2CE04510706	5.6	26.9	82.2	100
							2CE04511006	8.0	38.5	96.6	110
							2CE04511506	11.9	57.2	120.1	125
	2CE04512006	15.9	76.4	144.1	150						
	230-1-60	25.0	105	2.3	5.0	10.0	NONE	0.0	0.0	48.6	70
							2CE04510506	5.3	22.1	76.2	90
							2CE04510706	7.5	31.3	87.6	100
							2CE04511006	10.6	44.2	103.8	110
							2CE04511506	15.9	66.3	131.4	150
	2CE04512006	21.2	88.3	159.0	175						
	208-3-60	14.7	130	2.3	5.0	10.0	NONE	0.0	0.0	35.7	50
							2CE04510525 ²	4.0	11.1	49.6	60
							2CE04510725 ²	5.6	15.5	55.1	60
							2CE04511025	8.0	22.2	63.4	70
							2CE04511525	11.9	33.0	77.0	80
	2CE04512025	15.9	44.1	90.8	100						
	230-3-60	14.7	130	2.3	5.0	10.0	NONE	0.0	0.0	35.7	50
							2CE04510525 ²	5.3	12.7	51.6	60
							2CE04510725 ²	7.5	18.0	58.2	60
							2CE04511025	10.6	25.5	67.5	70
							2CE04511525	15.9	38.2	83.5	90
	2CE04512025	21.2	51.0	99.4	100						
460-3-60	7.7	64	1.3	2.2	5.0	NONE	0.0	0.0	18.2	25	
						2CE04510746 ²	6.8	8.2	28.4	30	
						2CE04511046 ²	10.1	12.1	33.4	35	
						2CE04511546 ²	13.6	16.4	38.7	40	
						2CE04512046 ²	19.5	23.5	47.5	50	
575-3-60	6.4	52	1.3	2.2	4.0	NONE	0.0	0.0	15.6	20	
						2CE04511058	10.6	10.2	28.4	30	
						2CE04511558	15.9	15.3	34.7	35	
2CE04512058	21.2	20.4	41.1	45							

1. HACR Type per NEC.

2. These electric heaters DO NOT include a fuse box. If a fuse box is required to meet a local code (i.e. Chicago), the fuse block accessories 2FB04700825 and 2FB04700846 are available for field installation.

TABLE 19: ELECTRICAL DATA - BQ060 DIRECT DRIVE WITH POWR'D CONVENIENCE OUTLET

Model Tonnage	Voltage	Compressors		OD Fan Motor FLA	ID Blower Motor FLA	Conv Outlet Amps	Electric Heater Model No.	Heater kW	Heater Amps	Minimum Circuit Ampacity Amps	Max Fuse / BRKR ¹ Size Amps
		RLA Each	LRA Each								
5	208-1-60	32.1	148	2.3	6.6	10.0	NONE	0.0	0.0	59.0	90
							2CE04510506	4.0	19.2	83.1	110
							2CE04510706	5.6	26.9	92.7	110
							2CE04511006	8.0	38.5	107.1	125
							2CE04511506	11.9	57.2	130.5	150
							2CE04512006	15.9	76.4	154.6	175
	2CE04513006	22.2	106.7	192.4	200						
	230-1-60	32.1	148	2.3	6.6	10.0	NONE	0.0	0.0	59.0	90
							2CE04510506	5.3	22.1	86.6	110
							2CE04510706	7.5	31.3	98.1	110
							2CE04511006	10.6	44.2	114.2	125
							2CE04511506	15.9	66.3	141.8	150
							2CE04512006	21.2	88.3	169.4	175
	2CE04513006	29.6	123.3	213.2	225						
	208-3-60	19.3	137	2.3	6.6	10.0	NONE	0.0	0.0	43.0	60
							2CE04510525 ²	4.0	11.1	56.9	70
							2CE04510725 ²	5.6	15.5	62.5	70
							2CE04511025	8.0	22.2	70.8	80
							2CE04511525	11.9	33.0	84.3	90
							2CE04512025	15.9	44.1	98.2	100
	2CE04513025	22.2	61.6	120.1	125						
	230-3-60	19.3	137	2.3	6.6	10.0	NONE	0.0	0.0	43.0	60
							2CE04510525 ²	5.3	12.7	59.0	70
							2CE04510725 ²	7.5	18.0	65.6	80
2CE04511025							10.6	25.5	74.9	80	
2CE04511525							15.9	38.2	90.8	100	
2CE04512025							21.2	51.0	106.8	110	
2CE04513025	29.6	71.2	132.0	150							
460-3-60	10.0	62	1.3	3.3	5.0	NONE	0.0	0.0	22.1	30	
						2CE04510746 ²	6.8	8.2	32.3	40	
						2CE04511046 ²	10.1	12.1	37.3	40	
						2CE04511546 ²	13.6	16.4	42.5	45	
						2CE04512046 ²	19.5	23.5	51.4	60	
						2CE04513046 ²	28.8	34.6	65.4	70	
575-3-60	7.9	50	1.3	3.3	4.0	NONE	0.0	0.0	17.6	25	
						2CE04511058	10.6	10.2	30.3	35	
						2CE04511558	15.9	15.3	36.7	40	
						2CE04512058	21.2	20.4	43.1	45	
						2CE04513058	30.4	29.3	54.1	60	

1. HACR Type per NEC.

2. These electric heaters DO NOT include a fuse box. If a fuse box is required to meet a local code (i.e. Chicago), the fuse block accessories 2FB04700825 and 2FB04700846 are available for field installation.

TABLE 20: ELECTRICAL DATA - BQ036 & 048 BELT DRIVE WITH POWR'D CONVENIENCE OUTLET

Model Tonnage	Voltage	Compressors		OD Fan Motor FLA	ID Blower Motor FLA	Conv Outlet Amps	Electric Heater Model No.	Heater kW	Heater Amps	Minimum Circuit Ampacity Amps	Max Fuse / BRKR ¹ Size Amps
		RLA Each	LRA Each								
3	208-1-60	19.0	105	1.7	7.6	10.0	NONE	0.0	0.0	43.0	60
							2CE04510506	4.0	19.2	67.1	80
							2CE04510706	5.6	26.9	76.7	80
							2CE04511006	8.0	38.5	91.1	100
							2CE04511506	11.9	57.2	114.6	125
	2CE04512006	15.9	76.4	138.6	150						
	230-1-60	19.0	105	1.7	7.6	10.0	NONE	0.0	0.0	43.0	60
							2CE04510506	5.3	22.1	70.7	80
							2CE04510706	7.5	31.3	82.1	90
							2CE04511006	10.6	44.2	98.3	100
							2CE04511506	15.9	66.3	125.9	150
	2CE04512006	21.2	88.3	153.5	175						
	208-3-60	11.9	85	1.7	5.2	10.0	NONE	0.0	0.0	31.8	40
							2CE04510525 ²	4.0	11.1	45.7	50
							2CE04510725 ²	5.6	15.5	51.2	60
							2CE04511025	8.0	22.2	59.5	60
							2CE04511525	11.9	33.0	73.1	80
	2CE04512025	15.9	44.1	86.9	90						
230-3-60	11.9	85	1.7	5.2	10.0	NONE	0.0	0.0	31.8	40	
						2CE04510525 ²	5.3	12.7	47.7	50	
						2CE04510725 ²	7.5	18.0	54.3	60	
						2CE04511025	10.6	25.5	63.6	70	
						2CE04511525	15.9	38.2	79.6	80	
2CE04512025	21.2	51.0	95.5	100							
460-3-60	5.9	42	1.0	2.6	5.0	NONE	0.0	0.0	16.0	20	
						2CE04510746 ²	6.8	8.2	26.2	30	
						2CE04511046 ²	10.1	12.1	31.2	35	
						2CE04511546 ²	13.6	16.4	36.4	40	
						2CE04512046 ²	19.5	23.5	45.3	50	
575-3-60	4.8	34	1	2	4.0	NONE	0.0	0.0	12.4	15	
						2CE04511058	10.6	10.2	25.1	30	
						2CE04511558	15.9	15.3	31.5	35	
2CE04512058	21.2	20.4	37.9	40							
4	208-1-60	25.0	105	2.3	7.6	10.0	NONE	0.0	0.0	51.2	70
							2CE04510506	4.0	19.2	75.2	90
							2CE04510706	5.6	26.9	84.8	90
							2CE04511006	8.0	38.5	99.2	110
							2CE04511506	11.9	57.2	122.7	125
	2CE04512006	15.9	76.4	146.7	150						
	230-1-60	25.0	105	2.3	7.6	10.0	NONE	0.0	0.0	51.2	70
							2CE04510506	5.3	22.1	78.8	90
							2CE04510706	7.5	31.3	90.2	100
							2CE04511006	10.6	44.2	106.4	110
							2CE04511506	15.9	66.3	134.0	150
	2CE04512006	21.2	88.3	161.6	175						
	208-3-60	14.7	130	2.3	5.2	10.0	NONE	0.0	0.0	35.9	50
							2CE04510525 ²	4.0	11.1	49.8	60
							2CE04510725 ²	5.6	15.5	55.3	60
							2CE04511025	8.0	22.2	63.6	70
							2CE04511525	11.9	33.0	77.2	80
	2CE04512025	15.9	44.1	91.0	100						
230-3-60	14.7	130	2.3	5.2	10.0	NONE	0.0	0.0	35.9	50	
						2CE04510525 ²	5.3	12.7	51.8	60	
						2CE04510725 ²	7.5	18.0	58.4	60	
						2CE04511025	10.6	25.5	67.7	70	
						2CE04511525	15.9	38.2	83.7	90	
2CE04512025	21.2	51.0	99.6	100							
460-3-60	7.7	64	1.3	2.6	5.0	NONE	0.0	0.0	18.6	25	
						2CE04510746 ²	6.8	8.2	28.8	30	
						2CE04511046 ²	10.1	12.1	33.8	35	
						2CE04511546 ²	13.6	16.4	39.1	40	
						2CE04512046 ²	19.5	23.5	47.9	50	
575-3-60	6.4	52	1.3	2	4.0	NONE	0.0	0.0	15.4	20	
						2CE04511058	10.6	10.2	28.2	30	
						2CE04511558	15.9	15.3	34.5	35	
2CE04512058	21.2	20.4	40.9	45							

1. HACR Type per NEC.

2. These electric heaters DO NOT include a fuse box. If a fuse box is required to meet a local code (i.e. Chicago), the fuse block accessories 2FB04700825 and 2FB04700846 are available for field installation.

TABLE 21: ELECTRICAL DATA - BQ060 BELT DRIVE WITH POWR'D CONVENIENCE OUTLET

Model Tonnage	Voltage	Compressors		OD Fan Motor FLA	ID Blower Motor FLA	Conv Outlet Amps	Electric Heater Model No.	Heater kW	Heater Amps	Minimum Circuit Ampacity Amps	Max Fuse / BRKR ¹ Size Amps
		RLA Each	LRA Each								
5	208-1-60	32.1	148	2.3	7.6	10.0	NONE	0.0	0.0	60.0	90
							2CE04510506	4.0	19.2	84.1	110
							2CE04510706	5.6	26.9	93.7	110
							2CE04511006	8.0	38.5	108.1	125
							2CE04511506	11.9	57.2	131.5	150
							2CE04512006	15.9	76.4	155.6	175
	2CE04513006	22.2	106.7	193.4	200						
	230-1-60	32.1	148	2.3	7.6	10.0	NONE	0.0	0.0	60.0	90
							2CE04510506	5.3	22.1	87.6	110
							2CE04510706	7.5	31.3	99.1	110
							2CE04511006	10.6	44.2	115.2	125
							2CE04511506	15.9	66.3	142.8	150
							2CE04512006	21.2	88.3	170.4	175
	2CE04513006	29.6	123.3	214.2	225						
	208-3-60	19.3	137	2.3	5.2	10.0	NONE	0.0	0.0	41.6	60
							2CE04510525 ²	4.0	11.1	55.5	70
							2CE04510725 ²	5.6	15.5	61.1	70
							2CE04511025	8.0	22.2	69.4	80
							2CE04511525	11.9	33.0	82.9	90
							2CE04512025	15.9	44.1	96.8	100
	2CE04513025	22.2	61.6	118.7	125						
	230-3-60	19.3	137	2.3	5.2	10.0	NONE	0.0	0.0	41.6	60
							2CE04510525 ²	5.3	12.7	57.6	70
							2CE04510725 ²	7.5	18.0	64.2	70
2CE04511025							10.6	25.5	73.5	80	
2CE04511525							15.9	38.2	89.4	90	
2CE04512025							21.2	51.0	105.4	110	
2CE04513025	29.6	71.2	130.6	150							
460-3-60	10.0	62	1.3	2.6	5.0	NONE	0.0	0.0	21.4	30	
						2CE04510746 ²	6.8	8.2	31.6	35	
						2CE04511046 ²	10.1	12.1	36.6	40	
						2CE04511546 ²	13.6	16.4	41.8	45	
						2CE04512046 ²	19.5	23.5	50.7	60	
						2CE04513046 ²	28.8	34.6	64.7	70	
575-3-60	7.9	50	1.3	2	4.0	NONE	0.0	0.0	16.5	20	
						2CE04511058	10.6	10.2	29.3	30	
						2CE04511558	15.9	15.3	35.6	40	
						2CE04512058	21.2	20.4	42.0	45	
						2CE04513058	30.4	29.3	53.1	60	

1. HACR Type per NEC.

2. These electric heaters DO NOT include a fuse box. If a fuse box is required to meet a local code (i.e. Chicago), the fuse block accessories 2FB04700825 and 2FB04700846 are available for field installation.

TABLE 22: PHYSICAL DATA

MODELS		BQ		
		036	048	060
EVAPORATOR BLOWER	Centrifugal Blower (Dia. x Wd. in.)	12 X 10	12 X 10	12 X 10
	Fan Motor HP (Direct Drive)	1/2	3/4	1
	Fan Motor HP (Belt Drive)	1 1/2	1 1/2	1 1/2
EVAPORATOR COIL	Rows Deep	4	3	3
	Fins Per Inch	16	15	15
	Face Area (Sq. Ft.)	4.3	5.1	5.1
CONDENSER FANS	Propeller Dia. (in.)	22	22	24
	Fan Motor Hp	1/3	1/2	1/2
	Nom. CFM	4300	4200	4500
CONDENSER COILS	Rows Deep	1	1	1
	Fins Per Inch	20	20	20
	Face Area (Sq. Ft.)	17.1	17.1	17.1
COMPRESSOR (Qty. Per Unit)	Reciprocating Type	1	1	1
AIR FILTERS	Quantity Per Unit (15" X 20" X 1" or 2")	2	2	2
	Quantity Per Unit (14" X 25" X 1" or 2")	1	1	1
	Total Face Area (sq. ft.)	6.6	6.6	6.6
CHARGE	Refrigerant 22 (lbs./oz.)	7/12	9/2	8/4

TABLE 23: ELECTRIC HEAT CORRECTION FACTORS

NOMINAL VOLTAGE	VOLTAGE	KW CAP. MULTIPLIER
208	208	1.00
240	230	0.92
480	460	0.92
600	575	0.92

TABLE 24: VOLTAGE LIMITATIONS¹

POWER SUPPLY	VOLTAGE	
	MIN.	MAX.
208/230-3-60	187	253
460-3-60	414	506
575-3-60	518	506

1. Utilization Range "A" in accordance with ARI Standard 110.

TYPICAL POWER WIRING

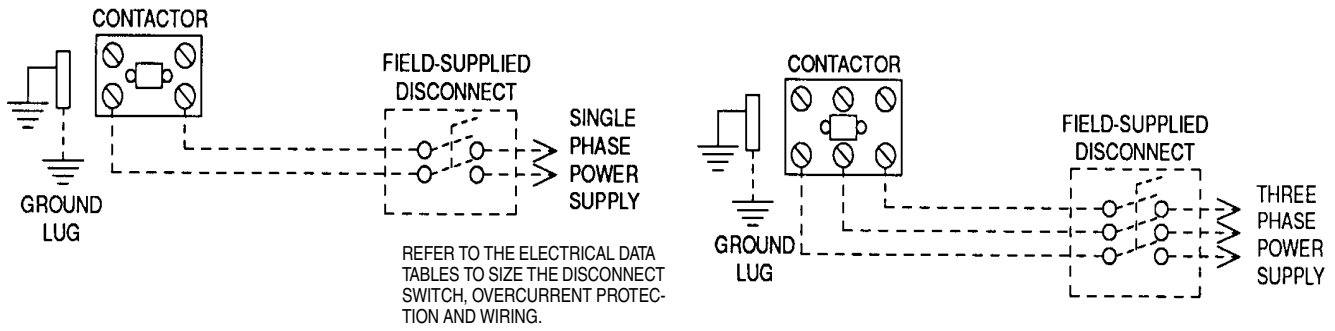

TYPICAL CONTROL WIRING

COOLING / HEATING (24 VOLT THERMOSTAT)

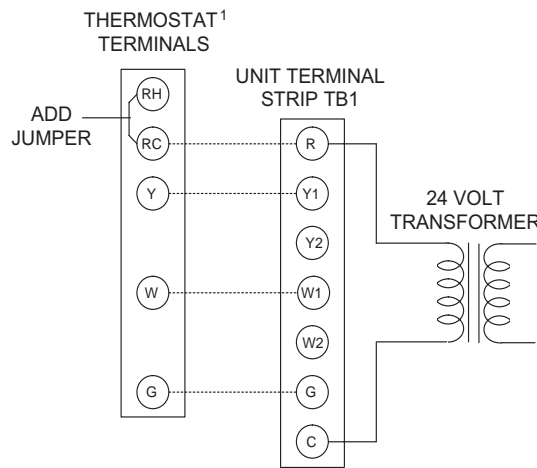

¹24 VOLT THERMOSTAT 2ET07701024. TO CONTROL THE ECONOMIZER ON THE SECOND STAGE COOLING OR TO HAVE AN ELECTRIC HEAT ACCESSORY WITH TWO STAGES OF HEAT, USE THERMOSTAT 2TH0471024.

COOLING / HEATING (ELECTRONIC THERMOSTAT) MULTI STAGE

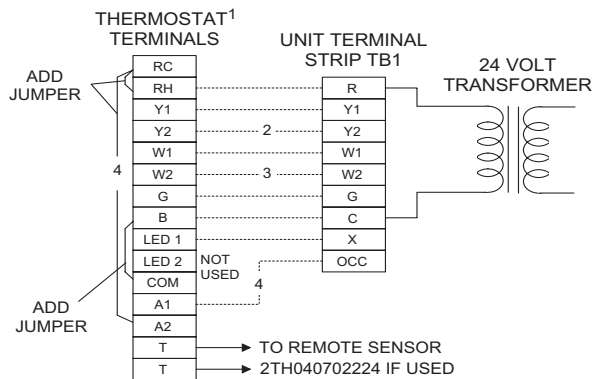

- ¹ ELECTRONIC PROGRAMMABLE THERMOSTAT 2ET04700224 (INCLUDES SUBBASE).
- ² SECOND STAGE COOLING IS NOT REQUIRED ON UNITS LESS ECONOMIZER.
- ³ SECOND STAGE HEATING IS ONLY REQUIRED ON UNITS WITH A TWO STAGE ELECTRIC HEATER.
- ⁴ REMOVE JUMPER J2 FROM TERMINALS 4 AND 9 ON JUMPER PLUG CONNECTOR P6 ON UNITS WITH ECONOMIZER. TERMINALS A1 AND A2 PROVIDE A RELAY OUT-PUT TO CLOSE THE OUTDOOR ECONOMIZER DAMPERS WHEN THE THERMOSTAT SWITCHES TO THE SET-BACK POSITION.

COOLING / HEATING (ELECTRONIC THERMOSTAT) SINGLE STAGE

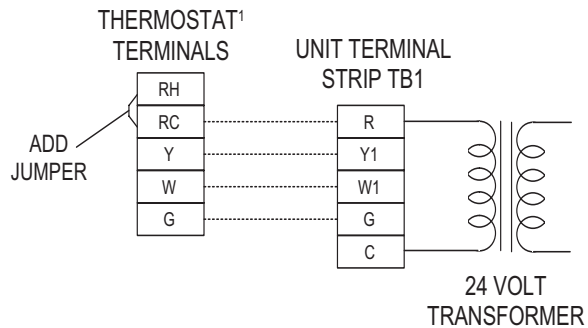

¹ELECTRONIC PROGRAMMABLE THERMOSTAT 2ET07701024 (INCLUDES SUBBASE). TO CONTROL THE ECONOMIZER ON SECOND STAGE COOLING, USE THERMOSTAT 2TH04700224.

FIGURE 2 - TYPICAL FIELD POWER & CONTROL WIRING

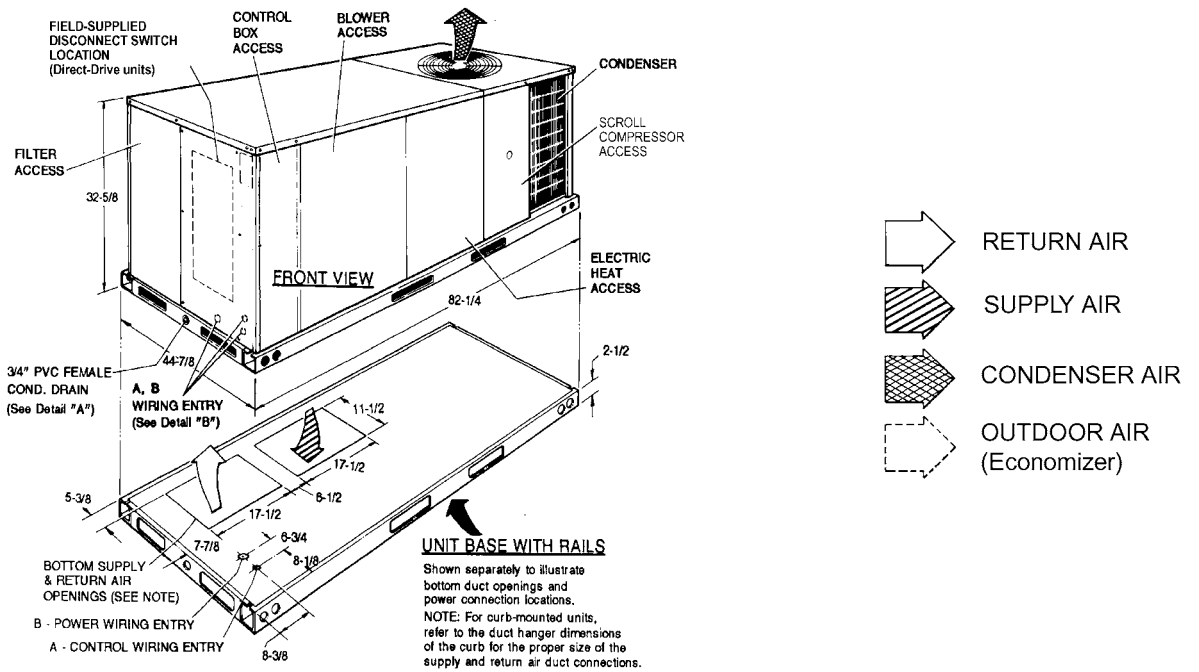

FIGURE 3 - UNIT DIMENSIONS (3 - 5 TON HEAT PUMP) FRONT VIEW

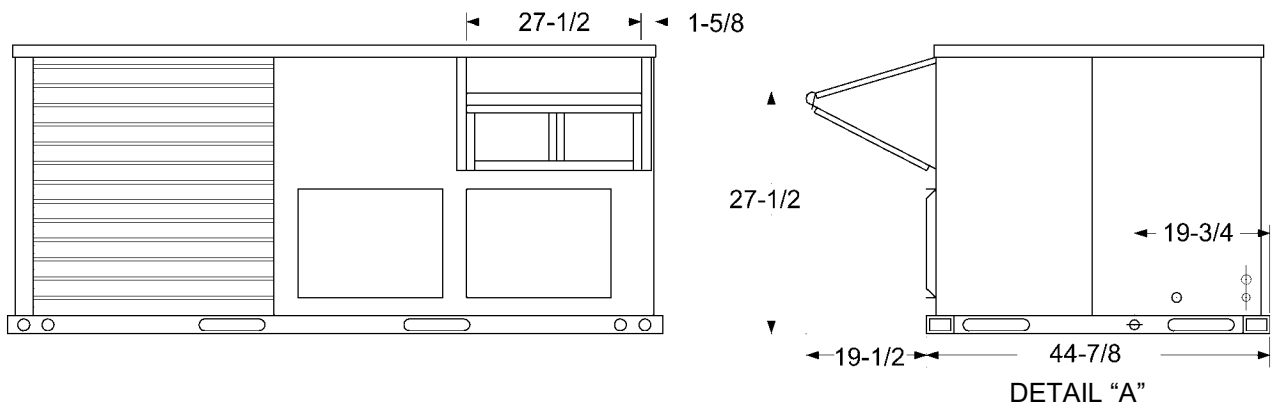

FIGURE 4 - UNIT WITH ECONOMIZER RAINHOOD

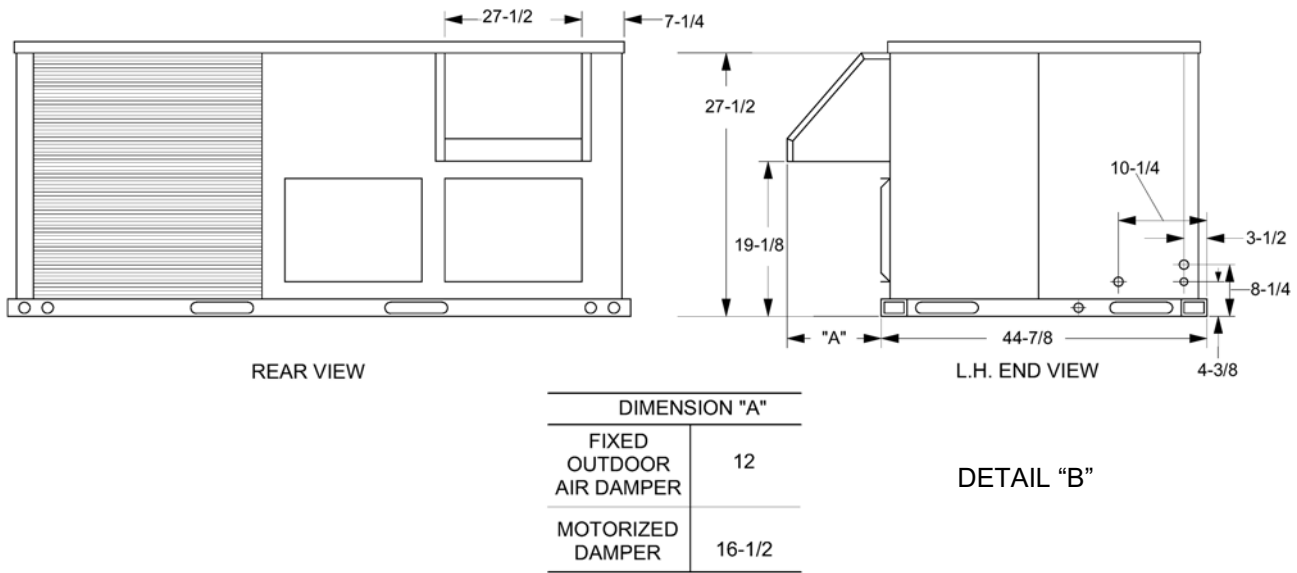

FIGURE 5 - UNIT WITH FIXED OUTDOOR AIR/MOTORIZED DAMPER RAINHOOD

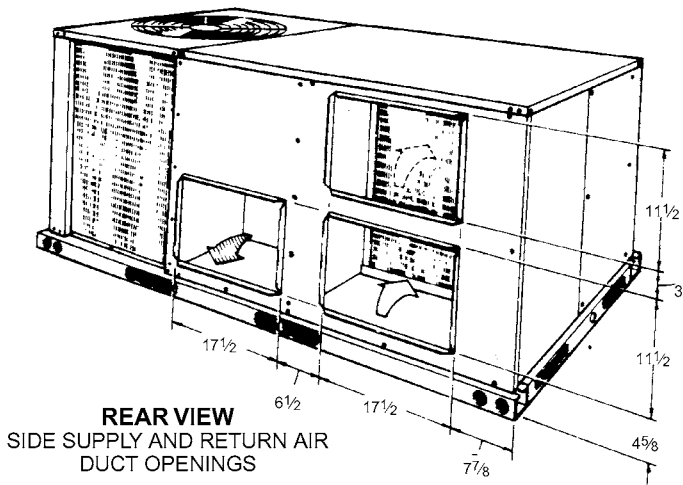

FIGURE 6 - UNIT DIMENSIONS (REAR VIEW)

DUCT COVERS - Units are shipped with all air duct openings covered.

For side duct applications;

1. Remove and discard the supply and return air duct covers.
2. Connect ductwork to duct flanges on the rear of the unit.

For bottom duct applications;

1. Remove the side supply air duct cover to gain access to the bottom supply air knockout panel.
2. Remove and discard the bottom knockout panel.
3. Replace the side duct cover.
4. With filter section access panel removed from the unit, remove and discard the bottom return air knockout panel.
5. Replace the filter access panel.

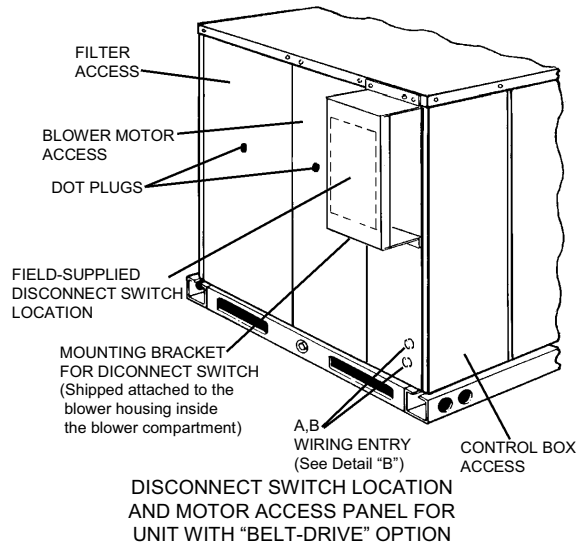

FIGURE 7 - DISCONNECT/BLOWER ACCESS LOCATION

TABLE 25: UTILITIES ENTRY

HOLE	OPENING SIZE (DIA.)	USED FOR
A	7/8" KO ¹	Control Wiring ²
		Side Bottom
B	2" KO ¹	Power Wiring
		Side Bottom
C	1-5/8" KO	Gas Piping (Front)
D	1-1/2" KO	Gas Piping (Bottom)

1. Opening in the bottom to the unit can be located by the side in the insulation.
2. Do not remove the 2" knockout ring.

TABLE 26: MINIMUM CLEARANCES

LOCATION	CLEARANCE
Front	24" (Cooling/Electric Heat) 32" (Gas Heat)
Rear	12" (Less Economizer) 36" (With Economizer or Fixed Air/Motorized Damper)
Left Side (Filter Access)	24" (Less Economizer) 36" (With Economizer)
Right Side (Cond. Coil)	24"
Below Unit ¹	0"
Above Unit ²	72" (For Condenser Air Discharge)

1. Units may be installed on combustible floors made from wood or class A, B, or C roof covering material.
2. Units must be installed outdoors. Overhanging structures or shrubs should not obstruct condenser air discharge outlet.

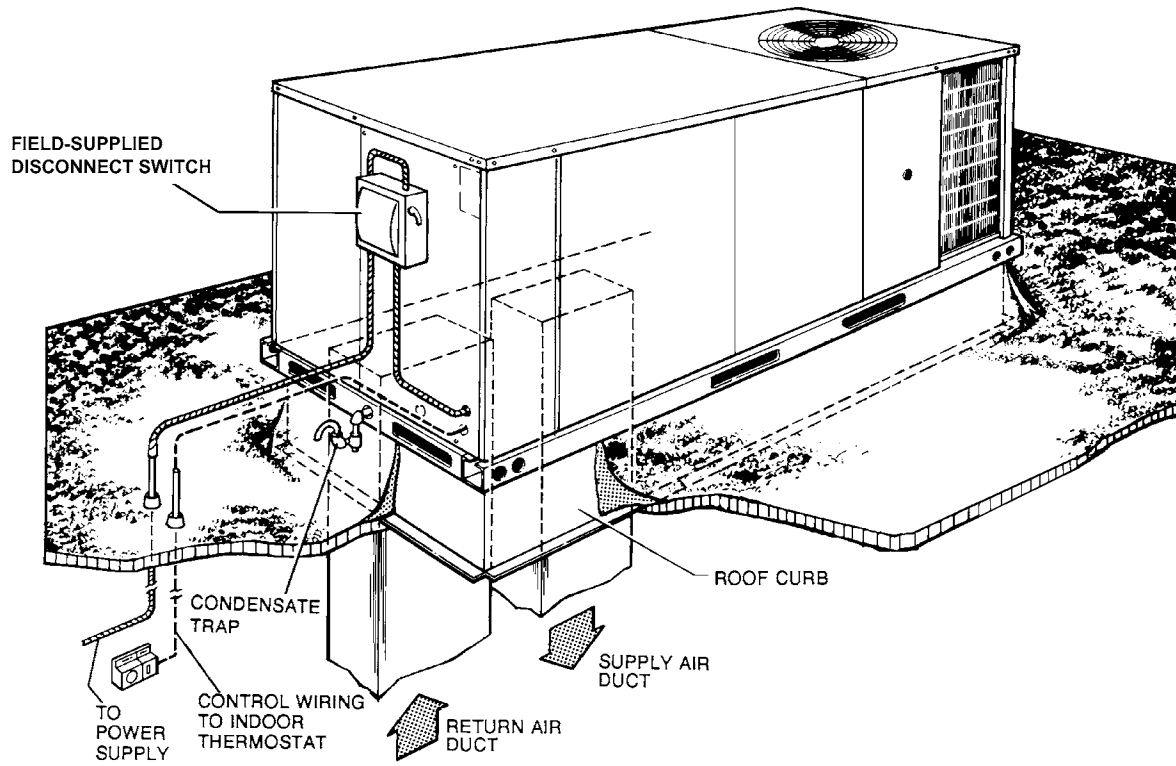
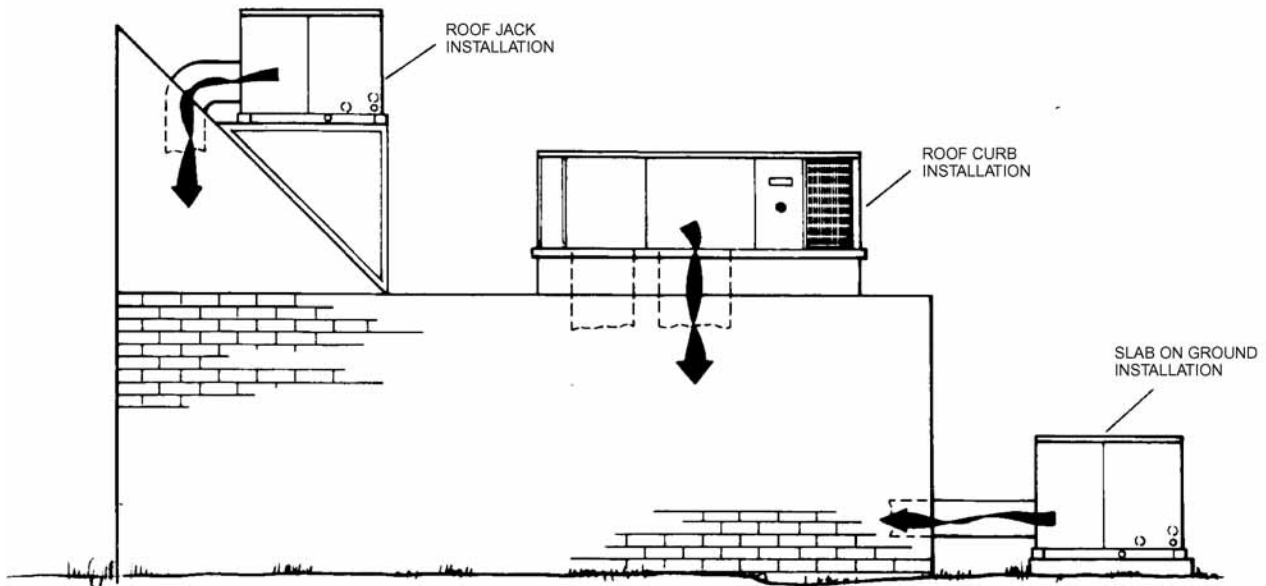

FIGURE 8 - TYPICAL APPLICATIONS

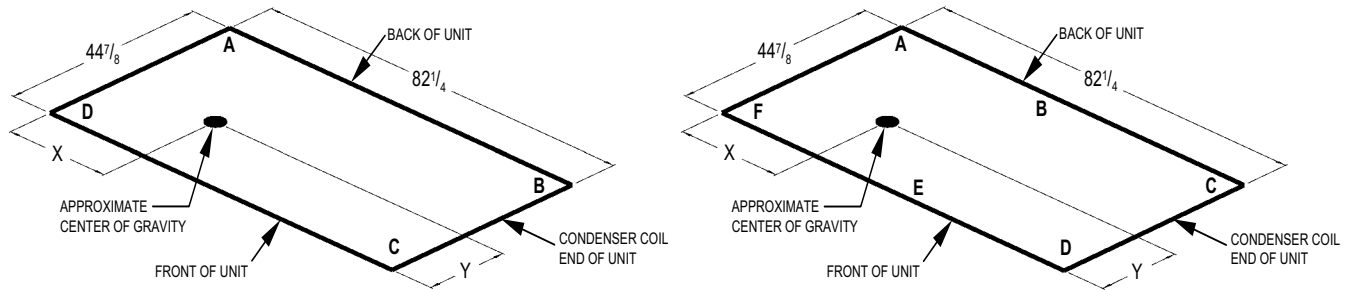

FIGURE 9 - FOUR AND SIX POINT LOADING

TABLE 27: BQ 4 POINT LOADS WEIGHT DISTRIBUTION

UNIT	TOTAL	A	B	C	D
BQ036	628	139	137	174	177
BQ048	668	148	146	185	189
BQ060	693	154	151	192	196

TABLE 28: BQ 6 POINT LOADS WEIGHT DISTRIBUTION

UNIT	TOTAL	A	B	C	D	E	F
BQ036	628	93	92	91	116	117	119
BQ048	668	99	98	97	123	125	126
BQ060	693	103	102	100	128	129	131

TABLE 29: CENTER OF GRAVITY

DIMENSION	3 - 5 TON
X	40-3/4"
Y	19-3/4"

TABLE 30: OPERATING WEIGHTS (LBS.)

MODEL SIZE		3 TON	4 TON	5 TON
BASIC UNIT	BQ	628	668	693
OPTIONS	Economizer	50		
	Motorized Damper	26		
	Electric Heater	5 - 7 kW		
		10 - 15 kW		
20 - 30 kW				
ACCY.	Roof Curb	92		
	Barometric Relief / Fixed Air Damper	10		
	Belt-Drive Blower	5		

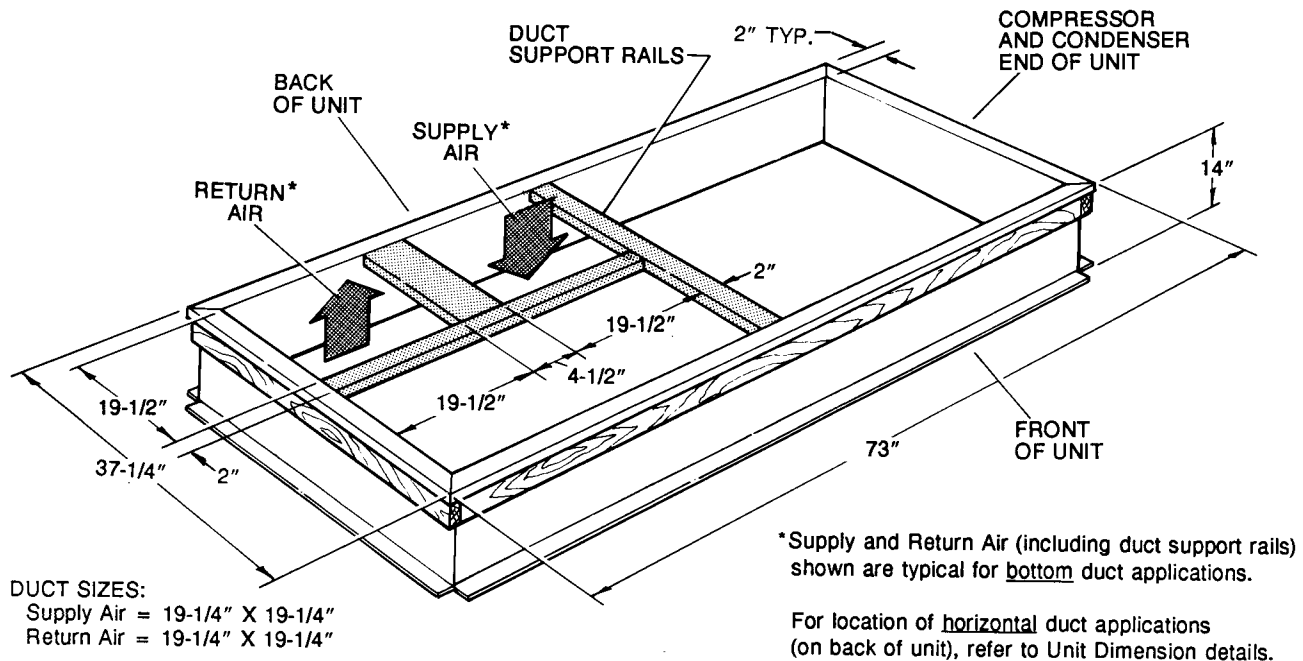

FIGURE 10 - ROOF CURB DIMENSIONS

GUIDE SPECIFICATIONS

GENERAL

Units shall be manufactured by York International Unitary Products Group in an ISO 9001 certified facility.

York's Sunline 2000™ units are convertible single package heat pumps. Although the units are primarily designed for curb mounting on a roof, they can also be slab-mounted at ground level or set on steel beams above a finished roof. Models are available with a wide variety of factory-mounted options and field-installed accessories to make them suitable for almost every application. All units are self-contained and assembled on full perimeter base rails with holes in the four corners for overhead rigging. Every unit is completely piped, wired, charged and tested at the factory to simplify the field installation and to provide years of dependable operation. All models (including those with an economizer) are suitable for either bottom or horizontal duct connections. Models with power exhaust are suitable for bottom duct connections only. For bottom duct, remove the sheet metal panels from the supply and return air openings through the base of the unit. For horizontal duct, remove the supply and return air panels on the rear of the unit.

All non-Scroll compressors include crankcase heaters and all compressors have internal pressure relief. Every refrigerant circuit includes a liquid line filter-drier, a discharge line high pressure switch and a suction line with a freezestat and low pressure/loss of charge switch. The unit control circuit

includes a 75 VA transformer, a 24-volt circuit breaker and a relay board with a compressor lockout circuit, a terminal strip for thermostat wiring, plus an additional set of pin connectors to simplify the interface of additional field controls. All units have long lasting powder paint cabinets with 750 hour salt spray test approval under ASTM B117 procedures. All models are CSA listed. All models include a 1-year limited warranty on the complete unit. Compressors and electric heater elements carry a 5-year warranty.

DESCRIPTION

Units shall be factory-assembled, single packaged heat pumps designed for outdoor mounted installation.

The units shall have minimum SEER ratings of 10.0. They shall have built-in field convertible duct connections for down discharge supply/return or horizontal discharge supply/return, and be available with factory installed options or field installed accessories. The units shall be factory wired, piped, charged with R-22 refrigerant and factory tested prior to shipment. All unit wiring shall be both numbered and color coded. All units the cooling performance shall be rated in accordance with DOE and ARI test procedures. Units shall be CSA listed, classified to ANSI Z21.47, UL 1995/CSA No. 236 standards.

UNIT CABINET

Unit cabinet shall be constructed of G90 galvanized steel, with exterior surfaces coated with a non-chalking, powdered paint finish, certified at 750 hours salt spray test per ASTM B117 standards. Indoor blower section shall be insu-

lated with a minimum 1/2" thick insulation, coated on the air-side. Aluminum foil faced insulation shall be used in the furnace compartment and be fastened with ridged fasteners to prevent insulation from entering the air stream. Cabinet panels shall be "large" size, easily removable for servicing and maintenance. Full perimeter base rails shall be provided to assure reliable transit of equipment, overhead rigging and proper sealing on roof curb applications. Disposable 1" filters shall be furnished and be accessible through a removable access door, sealed airtight. Units filter track shall be designed to accommodate either 1" or 2" filters. Fan performance measuring ports shall be provided on the outside of the cabinet to allow accurate air measurements of evaporator fan performance without removing panels or creating air bypass of the coils. Condensate pan shall be internally sloped and conform to ASHRAE 62-89 self-draining standards. Condensate connection shall be a minimum of 3/4" I.D. female and be a ridged mount connection.

INDOOR (EVAPORATOR) FAN ASSEMBLY

The indoor fan shall be direct drive, multi-speed, or a factory installed belt drive assembly that includes an adjustable pitch motor pulley. Job site selected (B.H.P.) brake horsepower shall not exceed the motors nameplate horsepower rating, plus the service factor. Units shall be designed not to operate above service factor. Fan wheel shall be double-inlet type with forward-curved blades, dynamically balanced to operate smoothly throughout the entire range of operation. Airflow design shall be constant air volume. Bearings shall be sealed and permanently lubricated for longer life and no maintenance.

OUTDOOR (CONDENSER) FAN ASSEMBLY

The outdoor fan shall be of the direct-driven propeller type, discharge air vertically, have aluminum blades riveted to a corrosion resistant steel spider bracket and shall be dynamically balanced for smooth operation. The outdoor fan motor shall be totally enclosed with permanently lubricated bearings, internally protected against overload conditions and staged independently.

REFRIGERANT COMPONENTS

Compressor:

- a. Shall be internally protected with internal high-pressure relief and over temperature protection.
- b. Shall have internal spring isolation and sound muffling to minimize vibration and noise, and be externally isolated on a dedicated, independent mounting.

Coils:

- a. Evaporator and condenser coils shall have aluminum plate fins mechanically bonded to seamless internally enhanced copper tubes with all joints brazed. Special Phenolic coating shall be available as a factory option.

- b. Evaporator and Condenser coils shall be of the direct expansion, draw-thru, design.

Refrigerant Circuit and Refrigerant Safety Components shall include:

- a. Independent fixed-orifice expansion devices.
- b. Filter drier/strainer to eliminate any moisture or foreign matter.
- c. Accessible service gage connections on both suction and liquid lines to charge, evacuate, and measure refrigerant pressure during any necessary servicing or troubleshooting without losing charge.
- d. The refrigeration system shall provide at least 15°F of sub-cooling at design conditions.

UNIT CONTROLS

- a. Unit shall be complete with self-contained low-voltage control circuit protected by a resettable circuit breaker on the 24-volt transformer side.
- b. Unit shall incorporate a lockout circuit which provides reset capability at the space thermostat or base unit, should any of the following standard safety devices trip and shut off compressor.
- c. Loss-of-charge/Low-pressure switch.
- d. High-pressure switch.
- e. Freeze-protection thermostat, evaporator coil.
- f. If any of the above safety devices trip, a LED (light-emitting diode) indicator shall flash a diagnostic code that indicates which safety switch has tripped.
- g. Unit shall incorporate "AUTO RESET" compressor over temperature, over current protection.
- h. Unit shall operate with conventional thermostat designs and have a low voltage terminal strip for easy hook-up.
- i. Unit control board shall have on-board diagnostics and fault code display.
- j. Standard controls shall include anti-short cycle and low voltage protection, and permit cooling operation down to 0°F.
- k. Control board shall monitor each refrigerant safety switch independently.
- l. Control board shall retain last 5 fault codes in non volatile memory, which will not be lost in the event of a power loss.

ELECTRIC HEATING SECTION

An electric heating section, with nickel chromium elements, shall be provided in a range of 5 thru 30 KW, offering two stages of capacity - 16 KW and above on 208/230 volt heaters and 20 KW and above on 460 and 575 volt heaters. The heating section shall have a primary limit control(s) and auto-

matic reset to prevent the heating element system from operating at an excessive temperature. The heating section assembly shall slide out of the unit for easy maintenance and service. Units with Electric Heating shall be wired for a single point power supply with branch circuit fusing (where required).

UNIT OPERATING CHARACTERISTICS

- a. Unit shall be capable of starting and running at 125°F outdoor temperature, exceeding maximum load criteria of ARI Standard 210/240. The compressor, with standard controls, shall be capable of operation down to 0°F outdoor temperature. Unit shall be provided with fan time delay to prevent cold air delivery before heat exchanger warms up (Gas heat only).

ELECTRICAL REQUIREMENTS

All unit power wiring shall enter unit cabinet at a single factory provided location and be capable of side or bottom entry, to minimize roof penetrations and avoid unit field modifications. Separate side and bottom openings shall be provided for the control wiring.

STANDARD LIMITED WARRANTIES

- Compressor 5 Years
- Electric Heat Element 5 Years
- Other Parts 1 Year

OPTIONAL OUTDOOR AIR (Shall be made available by either/or):

- **ELECTRONIC ENTHALPY AUTOMATIC ECONOMIZER**- Outdoor and return air dampers that are interlocked and positioned by a fully-modulating, spring return damper actuator. The maximum leakage rate for the outdoor air intake dampers shall not exceed 2% when dampers are fully closed and operating against a pressure differential of 0.5 IWG. A unit-mounted potentiometer shall be provided to adjust the outdoor and return air damper assembly to take in CFM of outdoor air to meet the minimum ventilation requirement of the conditioned space during normal operation. During economizer operation, a mixed-air temperature control shall modulate the outdoor and return air damper assembly to prevent the supply air temperature from dropping below 55°F. Changeover from compressor to economizer operation shall be provided by an integral electronic enthalpy control that feeds input into the basic module. The outdoor intake opening shall be covered with a rain hood that matches the exterior of the unit. Water eliminator/filters shall be provided. Simultaneous economizer/compressor operation is also possible. Dampers shall fully close on power loss.

- **MOTORIZED OUTDOOR AIR DAMPERS** - Outdoor air dampers are positioned by a 2-position, spring-return damper actuator. The maximum leakage rate for the outdoor air intake dampers shall not exceed 2% when dampers are fully closed and operating against a pressure differential of 0.5 IWG. A unit-mounted potentiometer shall be provided to adjust the outdoor damper assembly to take in the design CFM of outdoor air to meet the ventilation requirements of the conditioned space during normal operation. Whenever the indoor fan motor is energized, the dampers open up to one of two pre-selected positions - regardless of the outdoor air enthalpy. Dampers return to the fully closed position when the indoor fan motor is de-energized. Dampers shall fully close on power loss.

OTHER PRE-ENGINEERED ACCESSORIES AVAILABLE

- **ROOF CURB** - 14" and 8" high, full perimeter curb with wood nailer (shipped knocked-down).
- **BAROMETRIC RELIEF DAMPER** - Contains a rain hood, air inlet screen, exhaust damper and mounting hardware. Used to relieve internal air pressure through the unit.
- **POWER EXHAUST OPTION** - To work in conjunction with economizers.
- **ELECTRIC HEATERS**
- **ECONOMIZER/MOTORIZED DAMPER RAIN HOOD** - Contains all hood panels and the hardware for assembling.
- **MANUAL OUTDOOR AIR DAMPER**
- **COIL GUARD KIT** - Guard for cooling coil.
- **HAIL GUARD**

OTHER FACTORY INSTALLED OPTIONS

- **POWER EXHAUST OPTION** - To work in conjunction with economizers.
- **TECHNICOAT PHENOLIC COATED CONDENSER AND EVAPORATOR COIL**
- **ELECTRONIC SINGLE ENTHALPY ECONOMIZER**
- **DIRTY FILTER SWITCH**
- **PHASE MONITOR**
- **COIL GUARD**
- **POWERED GFI CONVENIENCE OUTLET**
- **NON-POWERED GFI CONVENIENCE OUTLET**

- **BAS CONTROLS (SImplicity™ INTELLI-Comfort™, CPC, JOHNSON, HONEYWELL, NOVAR)**
- **BAS READY ECONOMIZER (BELIMO ACTUATOR WITHOUT A CONTROLLER)**
- **HINGED FILTER DOOR ACCESS AND TOOLESS ACCESS PANELS**
- **STAINLESS STEEL DRAIN PAN**
- **BOTTOM DRAIN CONNECTION**
- **2" PLEATED FILTERS**
- **DISCONNECT SWITCH**
- **SUPPLY AIR SMOKE DETECTOR**
- **RETURN AIR SMOKE DETECTOR**

Subject to change without notice. Printed in U.S.A.
Copyright © 2004 by Unitary Products Group. All rights reserved.

036-21508-004-A-0504
Supersedes: 036-21508-003-A-0204

**Unitary
Products
Group**

**5005
York
Drive**

**Norman
OK
73069**